

STANDARDS/MANUALS/ GUIDELINES FOR SMALL HYDRO DEVELOPMENT

1.10

General–

Performance evaluation of small hydro power plants

Sponsor:

Ministry of New and Renewable Energy
Govt. of India

Lead Organization:

Alternate Hydro Energy Center
Indian Institute of Technology Roorkee

October 2012

Contact:

Dr Arun Kumar

Alternate Hydro Energy Centre,
Indian Institute of Technology Roorkee,

Roorkee - 247 667, Uttarakhand, India

Phone : Off.(+91 1332) 285821, 285167

Fax : (+91 1332) 273517, 273560

E-mail : aheciitr.ak@gmail.com, akumafah@iitr.ernet.in

DISCLAIMER

The data, information, drawings, charts used in this standard/manual/guideline has been drawn and also obtained from different sources. Every care has been taken to ensure that the data is correct, consistent and complete as far as possible.

The constraints of time and resources available to this nature of assignment, however do not preclude the possibility of errors, omissions etc. in the data and consequently in the report preparation.

Use of the contents of this standard/manual/guideline is voluntarily and can be used freely with the request that a reference may be made as follows:

AHEC-IITR, "1.10 General – Performance Evaluation of Small Hydro Power Plants", standard/manual/guideline with support from Ministry of New and Renewable Energy, Roorkee, Oct. 2012.

PREAMBLE

There are series of standards, guidelines and manuals on electrical, electromechanical aspects of moving machines and hydro power from Bureau of Indian Standards (BIS), Rural Electrification Corporation Ltd (REC), Central Electricity Authority (CEA), Central Board of Irrigation & Power (CBIP), International Electromechanical Commission (IEC), International Electrical and Electronics Engineers (IEEE), American Society of Mechanical Engineers (ASME) and others. Most of these have been developed keeping in view the large water resources/ hydropower projects. Use of the standards/guidelines/manuals is voluntary at the moment. Small scale hydropower projects are to be developed in a cost effective manner with quality and reliability. Therefore a need to develop and make available the standards and guidelines specifically developed for small scale projects was felt.

Alternate Hydro Energy Centre, Indian Institute of Technology, Roorkee initiated an exercise of developing series of standards/guidelines/manuals specifically for small scale hydropower projects with the sponsorship of Ministry of New and Renewable Energy, Government of India in 2006. The available relevant standards / guidelines / manuals were revisited to adapt suitably for small scale hydro projects. These have been prepared by the experts in respective fields. Wide consultations were held with all stake holders covering government agencies, government and private developers, equipment manufacturers, consultants, financial institutions, regulators and others through web, mail and meetings. After taking into consideration the comments received and discussions held with the lead experts, the series of standards/guidelines/manuals are prepared and presented in this publication.

The experts have drawn some text and figures from existing standards, manuals, publications and reports. Attempts have been made to give suitable reference and credit. However, the possibility of some omission due to oversight cannot be ruled out. These can be incorporated in our subsequent editions.

This series of standards / manuals / guidelines are the first edition. We request users to send their views / comments on the contents and utilization to enable us to review for further upgradation.

Standards/ Manuals/Guidelines series for Small Hydropower Development

| General | |
|---------------------------------|---|
| 1.1 | Small hydropower definitions and glossary of terms, list and scope of different Indian and international standards/guidelines/manuals |
| 1.2 Part I | Planning of the projects on existing dams, Barrages, Weirs |
| 1.2 Part II | Planning of the Projects on Canal falls and Lock Structures. |
| 1.2 Part III | Planning of the Run-of-River Projects |
| 1.3 | Project hydrology and installed capacity |
| 1.4 | Reports preparation: reconnaissance, pre-feasibility, feasibility, detailed project report, as built report |
| 1.5 | Project cost estimation |
| 1.6 | Economic & Financial Analysis and Tariff Determination |
| 1.7 | Model Contract for Execution and Supplies of Civil and E&M Works |
| 1.8 | Project Management of Small Hydroelectric Projects |
| 1.9 | Environment Impact Assessment |
| 1.10 | Performance evaluation of Small Hydro Power plants |
| 1.11 | Renovation, modernization and uprating |
| 1.12 | Site Investigations |
| Civil works | |
| 2.1 | Layouts of SHP projects |
| 2.2 | Hydraulic design |
| 2.3 | Structural design |
| 2.4 | Maintenance of civil works (including hydro-mechanical) |
| 2.5 | Technical specifications for Hydro Mechanical Works |
| Electro Mechanical works | |
| 3.1 | Selection of Turbine and Governing System |
| 3.2 | Selection of Generators and Excitation Systems |
| 3.3 | Design of Switchyard and Selection of Equipment, Main SLD and Layout |
| 3.4 | Monitoring, control, protection and automation |
| 3.5 | Design of Auxiliary Systems and Selection of Equipments |
| 3.6 | Technical Specifications for Procurement of Generating Equipment |
| 3.7 | Technical Specifications for Procurement of Auxiliaries |
| 3.8 | Technical Specifications for Procurement and Installation of Switchyard Equipment |
| 3.9 | Technical Specifications for monitoring, control and protection |
| 3.10 | Power Evacuation and Inter connection with Grid |
| 3.11 | operation and maintenance of power plant |
| 3.12 | Erection Testing and Commissioning |

PERSONS INVOLVED

1. Dr Arun Kumar, CSO & Principal Investigator, AHEC, IIT, Roorkee
2. Dr S K Singal, SSO & Investigator, AHEC, IIT, Roorkee

Drafting Group

1. Prof. H.K.Verma, IIT, Roorkee

Consultation Group

2. Dr Arun Kumar, AHEC, IIT, Roorkee
3. Dr S K Singal, AHEC, IIT, Roorkee
4. Mr. S.K.Tyagi, Consultant, AHEC, IIT, Roorkee
5. Mr. A.K.Chopra, MNRE, GOI, New Delhi
6. Mr. A.K.Singh, UJVNL, Dehradun
7. Mr. P.K.Singhal, UPJVNL, Lucknow
8. Mr. Pankaj Saxena, UPJVNL, Lucknow
9. Mr. Varshney, THDC, Rishikesh
10. Mr. V.K.Sharma, THDC, Rishikesh
11. Mr. U Ukhal, HPPCL, Himachal Pradesh
12. Mr. B.S.Saini, Gita Flopumps India Ltd., Saharanpur
13. Mr..S.S.Sidhu, HPP India Pvt. Ltd, Noida
14. Mr. K.C.Arora, Pentaflor Hydro power Ltd
15. Mr. P.K. Malohtra, Pentaflor Hydro power Ltd
16. Mr. Sanjeev Handu, Andritz Hydro power Ltd.
17. Mr. Vishnupad Saha, Andritz Hydro power Ltd.
18. Mr. Dinesh Rajput, Andritz Hydro power Ltd.
19. Mr. Pradeep Dube, Tanushree Hydropower Consultants, Noida
20. Mr. H.M.Sharma, Jyoti Ltd., Vadodra
21. Mr. Viral Mahida, Jyoti Ltd., Vadodra
22. Mr. Nishant Saha, Jyoti Ltd., Vadodra

CONTENTS

| ITEMS | PAGE NO |
|---|---------|
| Guidelines for Performance Evaluation of Small Hydro Power Plants | |
| 1.0 Objective | 1 |
| 2.0 Introduction | 1 |
| 3.0 Scope of Performance Evaluation | 1 |
| 4.0 References | 2 |
| 5.0 Visual Inspection | 3 |
| 6.0 Functional Checks | 4 |
| 7.0 Measurements and Tests | 4 |
| 7.1 Error Test on Measuring Instruments | 4 |
| 7.2 Operational Tests on Protective Relays | 4 |
| 7.3 Vibration Measurements | 5 |
| 7.4 Sound Level Measurements | 5 |
| 7.5 Load Rejection Test | 5 |
| 7.6 Maximum Power Output Test | 5 |
| 7.7 Unit Efficiency Test | 5 |
| 7.8 Methods of Unit Efficiency Measurement | 6 |
| 7.9 Measurement of Absolute Discharge | 7 |
| 7.10 Measurement of Net Head | 7 |
| 7.11 Measurement of Electrical Power Output | 12 |
| 7.12 Calculation of Unit Efficiency (Discharge Head Method) | 13 |
| 7.13 Calculation of Weighted Efficiency | 18 |
| 7.14 Index Test | 19 |
| 8.0 Methodology of Performance Evaluation | 20 |
| 9.0 Provisions to Facilitate Performance Testing | 20 |
| 9.1 General Guidelines | 21 |
| 9.2 Provisions for Pressure Measurement | 21 |
| 9.3 Provisions for Free Water Level Measurement | 25 |
| 9.4 Provisions for Absolute-Discharge Measurement in General | 25 |
| 9.5 Provisions for Absolute-Discharge Measurement by Current Meter Method | 26 |
| 9.6 Provisions for Absolute-Discharge Measurement using Weir | 31 |
| 9.7 Provisions for Absolute-Discharge Measurement by Ultrasonic (Acoustic) Methods | 34 |
| 9.8 Provisions for Relative-Discharge Measurement | 42 |
| 9.9 Provisions for Electrical Power Measurement | 48 |

LIST OF TABLES

| FIGURE NO. | TITLE | PAGE NO. |
|-------------------|--|-----------------|
| 1. | Averages of the Readings Taken for Efficiency Test of Kaplan Turbine | 14 |
| 2. | Unit Efficiency Calculations for Kaplan Turbine | 14 |
| 3. | Averages of the Readings Taken for Francis Turbine | 16 |
| 4. | Unit Efficiency Calculations for Francis Turbine | 16 |
| 5. | Averages of the Readings Taken for Pelton Turbine | 17 |
| 6. | Unit Efficiency Calculations for Pelton turbine | 18 |
| 7. | Methods for measurements differential pressure | 19 |

LIST OF FIGURES

| FIGURE NO. | TITLE | PAGE NO. |
|-------------------|---|-----------------|
| 1. | Low-head machine, differential pressure transducer | 9 |
| 2. | Low / medium head machine, separate pressure transducers | 10 |
| 3. | Low/medium head machine, level sensors | 10 |
| 4. | Vertical-axis Pelton turbine, pressure transducer at inlet | 11 |
| 5. | Horizontal-axis Pelton turbine, pressure transducer at inlet | 12 |
| 6. | Load-Efficiency Curve of the Generating Unit with Kaplan Turbine | 15 |
| 7. | Load-Efficiency Curve of the Generating Unit with Francis Turbine | 17 |
| 8. | Load-Efficiency Curve of the Generating Unit with Pelton turbine | 18 |
| 9. | Example of pressure taps | 23 |
| 10. | Pressure taps connected through separate connecting pips to box-type manifold | 24 |
| 11. | Pressure taps connected through ring-type manifold to pressure gauge | 24 |
| 12. | Details of measuring well | 26 |
| 13. | Temporary nozzle or bell-mouth placed in the intake of a low head turbine | 28 |
| 14. | Means for stabilizing flow in an open channel | 29 |
| 15. | Single vertical row of current meters fixed on a travelling winch | 30 |
| 16. | Frame supporting two rows of current meters moved up and down by a hoist | 30 |
| 17(a). | Frame lowered to submerge PCMs into water | 31 |
| 17(b) | Frame raised to pull PCMs out of water | 31 |
| 18. | Sketch of a rectangular sharp-crested weir | 32 |
| 19. | Locations of transducers for discharge measurement with UTTF | 36 |
| 20. | Typical arrangement of transducers in a circular conduit | 36 |
| 21. | Locations for measurement of dimension D | 37 |
| 22. | Measurement of discharge with DT-UTTF | 39 |

| TABLE NO. | TITLE | PAGE NO. |
|------------------|--|-----------------|
| 23. | ADCP Trolley | 40 |
| 24. | Guide rail fixed to the channel wall for guiding movement of ADCP trolley | 41 |
| 25. | Maneuvering ADCP trolley movement on the guide rail | 41 |
| 26. | Maneuvering V-ADCP from channel banks | 42 |
| 27. | Location of pressure taps in steel spiral case | 44 |
| 28. | Illustration of pressure taps in vertical steel spiral case | 44 |
| 29. | Location of pressure taps in concrete semi-spiral case | 45 |
| 30. | Upward slopping pipes and valves for purging | 46 |
| 31. | Location of taps in bulb turbine | 47 |
| 32. | Acoustic method of discharge measurement - Single path system | 48 |
| 33. | Acoustic method of discharge measurement - Double plane single path system | 48 |
| 34. | A Sample of TTB | 49 |
| 35. | TTB (shown with cover in place) fitted on the front of a control panel | 50 |
| 36. | Reference meter connected at TTB without opening the control panel | 50 |

LIST OF ANNEXURE

| ANNEXURE NO. | TITLE | PAGE NO. |
|---------------------|--|-----------------|
| 1. | Format of Power Station data to be supplied by Owner | 51 |
| 2. | Format of Generation data to be Supplied by Owner | 61 |

PERFORMANCE EVALUATION OF SMALL HYDRO POWER PLANTS

1.0 OBJECTIVE

Ministry of New and Renewable Energy (MNRE), Government of India (GOI) is giving high priority to quality and reliability of small hydro power (SHP) projects. Adopting quality standards is extremely important not only for ensuring a long life of small hydropower projects but also for their overall economic viability and optimum utilization of water discharge and head. With the introduction of performance evaluation of SHP stations as a mandatory requirement in 2003 for receiving subsidy from MNRE, all SHP projects in India are required to follow Indian / International standards in respect of construction, equipment and meeting the requirements in terms of specifications as well as performance parameters.

These guidelines have been prepared for the benefit of developers, designers and consultants, equipment manufacturers and owners of SHP projects as well as the performance evaluators of SHP plants, so that the ultimate purpose of performance evaluation stated in the preceding paragraph can be fulfilled effectively.

2.0 INTRODUCTION

Performance evaluation of a SHP plant/station includes broadly the following:

- (a) Inspection and qualitative checks to confirm that all parts, systems and auxiliaries in the power station are performing their assigned functions correctly.
- (b) Measurement and tests to confirm that the generating units are operating satisfactorily and efficiently, their operating parameters are within reasonable limits and the errors of protective relays and measuring instruments are within specified limits.

3.0 SCOPE OF PERFORMANCE EVALUATION

The overall scope of performance evaluation is divided below in 3 parts:

(a) Visual Inspection

- (i) General inspection
- (ii) Inspection of civil works including water conductor system
- (iii) Inspection of electrical and mechanical works and equipment
- (iv) Inspection of outdoor switchyard

(b) Functional Checks

- (i) Functional checks on simple devices.
- (ii) Operational checks on control and regulating devices /systems.

(c) Measurements and Tests

- (i) Error test on measuring instruments
- (ii) Operational tests on protective relays
- (iii) Vibration measurements
- (iv) Sound level measurements

- (v) Load rejection test
- (vi) Maximum power output test
- (vii) Unit efficiency test
- (viii) Index test

Performance evaluation is carried out in three stages: first of all the visual inspection, then the various functional checks and finally the measurements and tests.

It should be noted that the measurements and tests mentioned here are carried out subject to the technical feasibility and availability of provisions for the same in the power station. Furthermore, detailed diagnostic investigations on any faulty component/system are kept outside the scope of performance evaluation.

4.0 REFERENCES

RELEVANT CODES AND STANDARDS

Some Indian/ International standards, guidelines and codes of relevant to the subject are listed below, which may be referred to for getting more details where needed:

| | | | |
|-----|------------------|---|--|
| R1 | IEC-60041-1991 | : | Field Acceptance Tests to Determine the Hydraulic Performance of Turbines, Storage Pumps and Pump Turbines (adopted by Bureau of Indian Standards as IS/IEC-41) |
| R2 | IEC-61116-1992 | : | Electromechanical Equipment Guide for Small Hydroelectric Installations |
| R3 | IEC-62006-2010 | : | Hydraulic Machines - Acceptance Tests of Small Hydroelectric Installations |
| R4 | IEC-60545-1976 | : | Guide for Commissioning, Operation and Maintenance of Hydraulic Turbines |
| R5 | IS-12800-1991 | : | Guidelines for Selection of Hydraulic Turbine: Preliminary Dimensioning and Layout of Surface Hydroelectric Power Houses, Part 3: Small, Mini and Micro Hydroelectric Power Houses |
| R6 | IEC-60308-1970 | : | Testing of Speed of Governing Systems for Hydraulic Turbines |
| R7 | IEEE-421-1972 | : | Criteria and Definitions for Excitation Systems for Synchronous Machines |
| R8 | IEEE-421A-1978 | : | IEEE Guide for Identification, Testing and Evaluation of the Dynamic Performance of Excitation System |
| R9 | ASME PTC-29-2005 | : | Performance Test Code for Speed-Governing Systems for Hydraulic Turbine-Generator Units |
| R10 | IEC-60034-1-2004 | : | Rotating Electrical Machines – Part 1: Rating and Performance |
| R11 | IS-4722-2001 | : | Rotating Electrical Machines |
| R12 | IS-3231-1-1965 | : | Electrical Relays for Power System Protection – Part 1: General Requirements |
| R13 | IS-8686-1977 | : | Static Protective Relays |

| | | | |
|-----|---------------------------------|---|--|
| R14 | IEC-60255-6-1988 | : | Electrical Relays - Part 6: Measuring Relays and Protection Equipment |
| R15 | IS-11726/ISO-2954 (1975) | : | Requirements for Instruments for Measuring Vibration Severity of Rotating and Reciprocating Machines |
| R16 | ISO-10816-1-1995 | : | Mechanical Vibration – Evaluation of Machine Vibration by Measurements on Non-Rotating Parts – Part 1: General Guidelines |
| R17 | IS-11727(1985-Reaffirmed 1996) | : | Measurement and Evaluation of Vibration Severity in Situ of Large Rotating Machines with Speed Range from 10 to 200 rev/s |
| R18 | ISO-1680-1986 | : | Acoustics – Test Code for the Measurement of Airborne Noise Emitted by Rotating Electrical Machinery |
| R19 | ISO-2954-1975 | : | Mechanical Vibration of Rotating and Reciprocating Machinery Requirements for Instruments for Measuring Vibration Severity |
| R20 | IEC-60034-9-2003 | : | Rotating Electrical Machines - Part 9: Noise Limits |
| R21 | IS-2705 (1992, Reaffirmed 1997) | : | Current Transformers |
| R22 | IS-3156-1992, Reaffirmed 1997) | : | Voltage Transformers |
| R23 | IEC-61362-1998 | : | Guide to Specification of Hydraulic Turbine Control Systems |
| R24 | IS-2026-1997 | : | Power Transformers |
| R25 | AHEC-2009 | : | Performance Testing of SHP stations; A guide for Developers, Manufacturers and Consultants, AHEC IIT Roorkee Dec 2009 |

Abbreviations:

| | | |
|------------|---|--|
| ASME | : | American Society of Mechanical Engineers |
| AHEC, IITR | : | Alternate Hydro Energy Centre, Indian Institute of Technology, Roorkee |
| IEC | : | International Electro-technical Commission |
| IEEE | : | Institute of Electrical & Electronic Engineers |
| IS | : | Indian Standard |
| ISO | : | International Organization for Standardisation |

5.0 VISUAL INSPECTION

In the first stage of performance evaluation, a visual inspection of each and every part and subsystem may be carried out while the power station is running, and any shortcomings should be recorded. The following parts / subsystems may be included in the inspection:

- i. Access to power house, intake works, penstock, power channel, headrace channel, tailrace channel etc. (as applicable).
- ii. Communication facilities and general facilities available in the power station.
- iii. Safety measures and warnings.
- iv. General upkeep, operation and maintenance of the power station.

- v. Complete water conductor system, starting from water intake to the tailrace discharging into main stream of water.
- vi. Complete civil construction works, including intake works, power house building, diversion / bypass works etc.
- vii. Generating units, their ratings, controls etc.
- viii. Control room, switchgear room, battery room, machine hall etc.
- ix. Station auxiliaries
- x. Switchyard
- xi. Power evacuation arrangement.

6.0 FUNCTIONAL CHECKS

In the second stage of performance evaluation, necessary qualitative checks may be carried out with an objective of verifying the operation / functioning of the following components / subsystems and shortcomings / defects, if any, should be recorded:

- i. **Control Panels:** Functional checks on external accessories (lamps, push buttons, switches, digital indicators, buzzers, hooters etc.) and internal accessories (panel lights, panel light switches, space heaters, thermostats etc.).
- ii. **Fault / Status Annunciators:** Component check, test, accept and reset functions.
- iii. **Circuit Breakers:** Trip and close functions.
- iv. **Master / Trip / Auxiliary Relays:** Operate and reset functions.
- v. **Control / Regulating Devices:** Flow / head regulating devices, excitation voltage control, speed governor control, power factor control, parallel operation of generating units, manual start / stop operations, manual / auto synchronization, local / remote control of transformer tap changer, etc.

7.0 MEASUREMENTS AND TESTS

The following measurements and tests are recommended in the third and final stage of performance evaluation:

7.1 Error Test on Measuring Instruments

All electrical panel meters (analog / digital ammeters, voltmeters, kilowatt-, power factor, meters, energy meters, frequency meters and digital multi-function meters) are subjected to a limited error check. The readings of these meters at the respective operating points are compared against a portable reference meter to measure their errors at the current (prevailing) operating points. If a meter is found to have an error beyond its accuracy class, its recalibration or replacement should be recommended.

A similar check is carried out on speed indicator. Comparison may be made against a reference frequency meter because of the higher resolution and accuracy of reference frequency meters.

7.2 Operational Tests on Protective Relays

A portable secondary injection test set is used to test all the measuring relays or different relay functions of multi-function digital relays as per relevant standards. Normally it is considered sufficient to carry out operating-value and operating-time tests (the latter for

time delay relays and delay elements only) at the current (prevailing) relay settings. In case of the doubtful working of a relay, a more detailed secondary injection test may be conducted.

It may be sufficient to test the management relays for their measurement functions only.

7.3 Vibration Measurements

Vibrations are measured with the help of a vibration meter at each bearing of the generating units on no-load condition as well as full-load condition. Both rms displacement and rms velocity of the vibrations in the frequency band of the 1 Hz to 1 kHz are measured, if possible at four mutually perpendicular locations on the bearing, and both along axial and radial directions. Excessive vibrations, if any, should be brought to the notice of the power station owner.

7.4 Sound Level Measurements

Sound level is measured with the help of a sound level meter in “weighting factor A” mode near the machines at no-load conditions. Readings are taken 1 m away from the surface of generator, turbine, flywheel and gear box (as applicable) at right angle to the machine shaft, both on upstream and downstream sides of the machine. A maximum sound level upto 85 dB is generally desirable and a level of 90 dB is considered acceptable. Sound levels beyond 90 dB will cause discomfort to the operation and maintenance (O&M) staff working close to the machine, while a continuous exposure to sound levels above 95 dB can seriously affect their working efficiency and even cause deafness in them.

7.5 Load Rejection Test

The generating unit under test is initially loaded to its rated value and its speed is noted down. The maximum sound level near the machine is also recorded on the basis of sound level test (Section 7.4). The load on the machine is then suddenly rejected using the emergency shutdown push-button switch and the peak values of the speed and sound level (at the same point) attained consequently are noted. The maximum rise in the speed should be within the run-away speed of the generator as specified by its manufacturer.

7.6 Maximum Power Output Test

The test is conducted to check whether the maximum electrical power output actually available from the generating unit matches with the value specified by the manufacturer. As far as possible, the test is conducted at the rated head or at the head / discharge specified for maximum output of the generating unit.

7.7 Unit Efficiency Test

The test of efficiency of the complete generating units is the most difficult, expensive and time consuming part of the performance evaluation exercise. Therefore, it may be sufficient to test only one generating unit in the SHP station if there are more than one identical units in the same power station.

The mandate of various standards on carrying out the efficiency test on the turbine/generating unit of SHP plants is explained briefly below:

(a) IEC-60041

IEC-60041 (1991): which has an apparent focus on large machines, does not make an explicit mention of small hydroelectric installations. However, it leaves the decision of conducting efficiency test to the parties concerned by stating that “the decision to perform field acceptance tests including the definition of their scope is the subject of an agreement between the purchaser and the supplier of the machine”.

(b) IEC-61116

IEC-61116 (1992): which “applies to hydroelectric installations with units having power outputs less than 5 MW and turbines with nominal runner diameters less than 3 m”, hints that the efficiency value/test may not be covered under guarantees in the following cases:

- (1) When the efficiency value is not of real use as the available water flow greatly exceeds the useable flow.
- (2) When it is technically difficult or prohibitively expensive to carry out the test.

(c) IEC-62006

IEC-62006 (2010): which “applies to installations containing impulse or reaction turbines with unit power up to about 15 MW and reference diameter of about 3 m”, divides these small hydroelectric installations on the basis of “the tests required for acceptance of the hydraulic turbine” into the following three classes:

Class A: Normal test program (**Default**): To determine the maximum power output of the installation (*which means, maximum power output test*).

Class B: Extended test program (**Recommended**): To determine the performance characteristics of the installation (*which means, index test*).

Class C: Comprehensive test program (**Optional**): To determine the absolute efficiency of the installation (*which means, turbine efficiency test*).

NOTE: All classes contain safety tests, trial operating tests and reliability tests.

7.8 Methods of Unit Efficiency Measurement

One of the following two methods, recommended by IEC-60041, can be used for the efficiency measurement:

7.8.1 Unit efficiency measurement by discharge head method

Efficiency of a generating unit is given by the ratio of the electrical power output of the generator (P_e) to the hydraulic power input to the turbine (P_h). It includes the losses in the turbine (along with its draft tube and auxiliaries), in the generator (along with its excitation system) and in the speed increaser unit, if present.

The hydraulic power input to the turbine is given by

$$P_h = \rho g HQ \quad \text{in watts}$$

where

- ρ = actual density of water in the turbine in kg/m^3
- g = actual acceleration due to gravity of earth at the site in m/s^2
- H = net head in m
- Q = discharge rate in m^3/s

Thus, this method involves measurement of (a) the absolute value of the discharge through the turbine, (b) the net water head available at the turbine, and (c) the electrical power output of the machine, all under specified operating conditions and each with high accuracy. Details of these measurements are discussed in Sections 7.9, 7.10 and 7.11, respectively. The method is specially suited to efficiency measurement of the complete generating unit.

7.8.2 Turbine Efficiency Measurement by Thermodynamic Method

In the case of SHP stations of high heads (100 m and above), the hydraulic efficiency of the turbine can be measured by thermodynamic method. It involves accurate measurement of the small temperature rise of water that takes place between intake and outlet of the turbine and the pressure measurement, but does not require discharge measurement. The overall efficiency of the generating unit is determined by assessing the mechanical losses in the turbine and in its auxiliaries and losses in the generator. Thus the method is not very suitable when efficiency of the complete generating unit (not the turbine alone) is required to be measured.

7.9 Measurement of Absolute Discharge

The IEC Standard 60041 specifies the following methods of discharge measurement:

- (a) Current-meter method
- (b) Pitot-tube method
- (c) Pressure-time method
- (d) Tracer method
- (e) Weirs
- (f) Differential pressure devices
- (g) Volumetric gauging method
- (h) Acoustic method

The choice of the method of discharge measurement may be affected, as per the IEC Standard 60041, by the following factors:

- (a) Limitations imposed by the design of the plant
- (b) Cost of special equipment and its installation
- (c) Limitations imposed by plant operating conditions, for example draining of the system, constant load or discharge operation, etc.

7.10 Measurement of Net Head

Measurement of net head requires measurement of total head at the inlet and that at the outlet, respectively, of the turbine and using their difference.

This in turn requires the following:

- (a) Reference level marking,
- (b) Measurement of either the pressure head or the free water-surface level, both at inlet and outlet points, and
- (c) Calculation of the velocity head at both the points from the discharge rate measured separately.

Where practically feasible, the difference pressure head can be measured directly by connecting a differential pressure gauge between the inlet and the outlet.

The measurement methods as specified in the IEC Standard 60041 are listed below:

a) Head Measurement in Pressure Channels

1. Liquid column manometer
2. Dead weight manometer
3. Spring pressure gauge
4. Electronic pressure transducer /transducers

b) Head Measurement in Open Channels

1. Liquid column nanometer
2. Gas purge (bubbler) method
3. Immersible pressure transducer

c) Free Water-Surface-Level Measurement in Open Channels

1. Plate gauge
2. Point / hook gauge
3. Float gauge
4. Staff gauge
5. Ultrasonic level sensors

Use of electronic pressure transducers for head measurement in pressure channels, electronic immersible pressure gauges for head measurement in open channels and ultrasonic level sensors for free water-surface-level measurement in open channels has been found to be most convenient and leads to the most accurate results.

The relations involved in calculating the net head (H) for five different cases (situations) are given in the following sub-sections. In each case, the terms involved are illustrated by a figure taken from IEC-60041.

7.10.1 Low Head Machine, Differential Pressure Transducer (Case 1)

As illustrated in Fig 1, a differential pressure transducer is connected between the inlet and outlet points of the turbine, the latter one being the draft-tube opening. This is the simplest method of net head measurement, but rarely feasible in practice. The net head in this case is given by:

$$H = \frac{\Delta p}{\rho g} + \frac{v_1^2 - v_2^2}{2g}$$

where

Δp is the reading of the differential pressure transducer in Pa ,

v_1 and v_2 are the water velocities in m/s at the inlet and outlet points, respectively,
 ρ is the actual water density, and
 g is the value of the acceleration due to earth's gravity at the site.

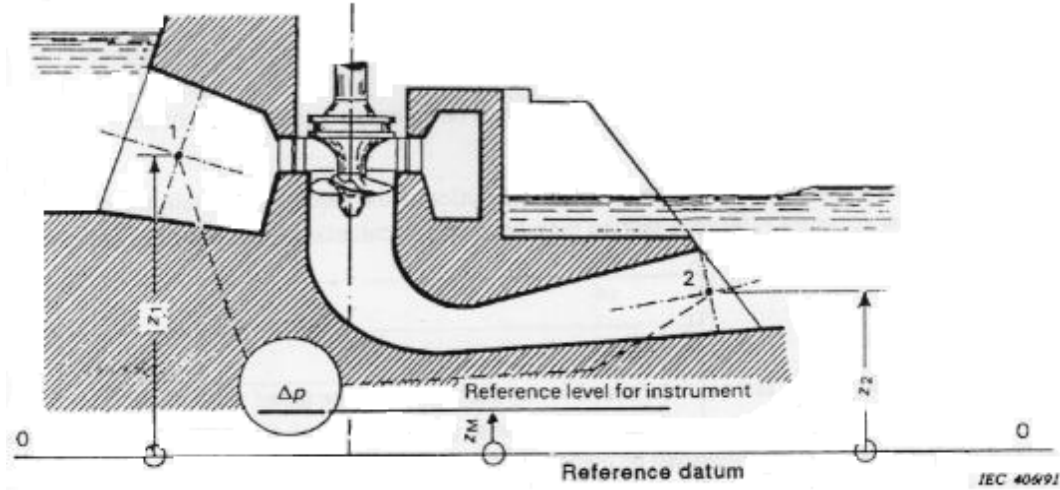

Fig. 1: Low-head machine, differential pressure transducer

Source: IEC-60041

1: Inlet point (CL of penstock), 2: Outlet point (CL of DT exit)

7.10.2 Low/Medium Head Machine, Separate Pressure Transducers (Case 2)

In most of cases, it is not practically possible to connect one (differential) pressure transducer between the inlet and outlet points. In such cases, two separate (gauge) pressure transducers are connected, one at the inlet and the other at the outlet, as illustrated in Fig 2. The net head available by the turbine is then given by

$$\begin{aligned}
 H &= \left[z_1' + \frac{p_1'}{\rho g} + \frac{v_1^2}{2g} \right] - \left[z_2' + \frac{p_2'}{\rho g} + \frac{v_2^2}{2g} \right] \\
 &= \left(z_1' - z_2' \right) + \left[\frac{p_1' - p_2'}{\rho g} \right] + \left(\frac{v_1^2 - v_2^2}{2g} \right)
 \end{aligned}$$

where

p_1' and p_2' are the readings of the two pressure transducers in Pa installed at the inlet and outlet points, respectively, and

z_1' and z_2' are the elevations of the pressure transducers above a common reference (say above MSL).

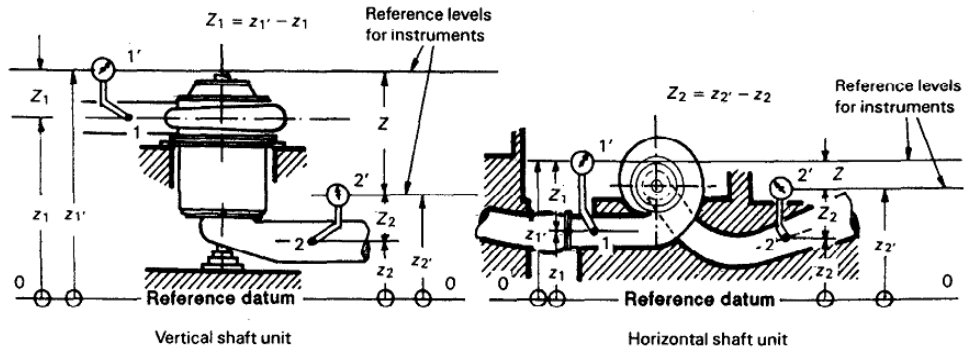

Fig. 2 : Low / medium head machine, separate pressure transducers

Source: IEC-60041

- 1: Inlet point (CL of penstock), 2: Outlet point (CL of DT exit)
 1': Reference level for pressure gauge at inlet, 2': same at outlet

7.10.3 Low/Medium Head Machine, Level Sensors (Case 3)

Where the headrace and tailrace are open channels, free-surface water levels need to be measured separately near the intake point and the opening of the draft tube as illustrated in Fig 3. The net head is given by

$$H = \left[z_1'' + \frac{v_1^2}{2g} \right] - \left[z_2'' + \frac{v_2^2}{2g} \right]$$

where,

z_1'' and z_2'' are the = $(z_1'' - z_2'')$ + $\left(\frac{v_1^2 - v_2^2}{2g} \right)$ r in m measured with the level sensors,
 and

v_1 and v_2 are the flow velocities at the aforesaid locations in m/s.

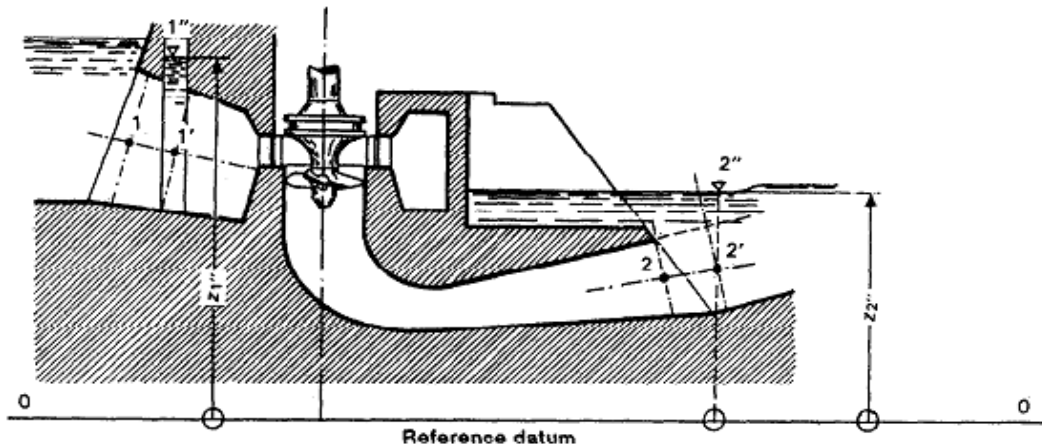

Fig. 3: Low/medium head machine, level sensors

Source: IEC-60041

- 1: Intake point, 2: Opening of DT
 1': Measurement point at intake, 2': Measurement point at outlet

7.10.4 Vertical-Axis Pelton Turbine (Case 4)

As the Pelton turbines release water at atmospheric pressure, i.e. zero gauge pressure, only the inlet pressure needs to be measured. For this purpose, a gauge pressure transducer is connected to the penstock at the inlet to the turbine as shown in Fig 4. The net head availed by the turbine is given by

$$H = \left[z_1' + \frac{p_1'}{\rho g} + \frac{v_1^2}{2g} \right] - (z_2)$$

$$= \frac{p_1'}{\rho g} + z + \frac{v_1^2}{2g}$$

where,

z_1' is the elevation of the pressure transducer in m,

p_1' is the reading of the pressure transducer in Pa,

v_1 is the velocity of water at the inlet to turbine in m/s,

z_2 is the elevation of the centre-line of the runner in m, and

$z = z_1' - z_2$

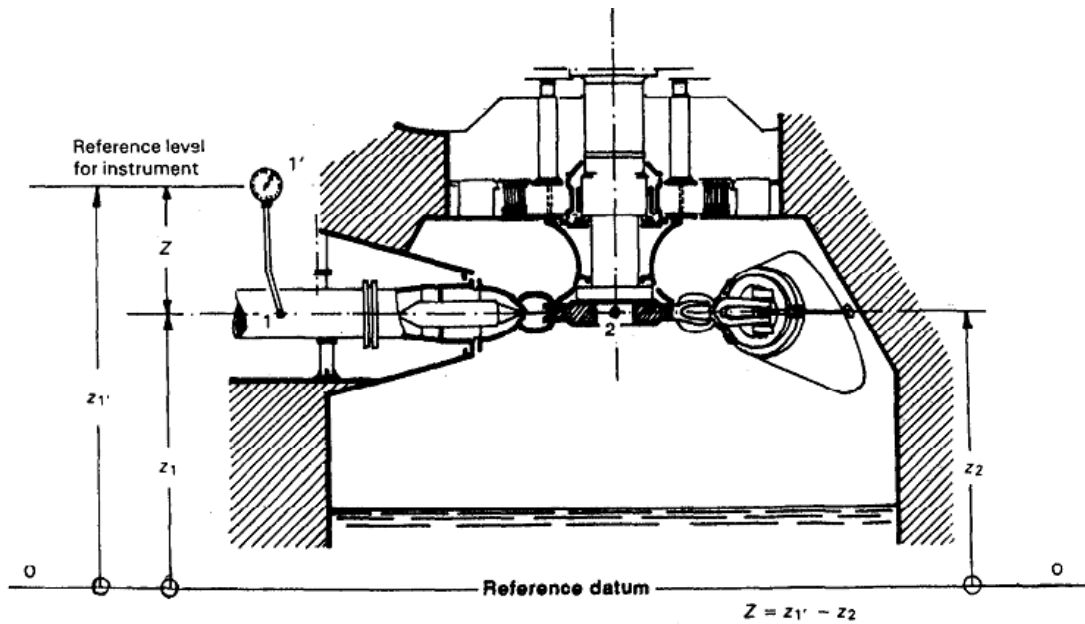

Fig. 4 : Vertical-axis Pelton turbine, pressure transducer at inlet

Source: IEC-60041

1: Inlet point (Centre line of penstock)

1': Reference level for pressure gauge at inlet, 2: Centre line of runner

7.10.5 Horizontal-Axis Pelton Turbine (Case 5)

In this case too, only the inlet pressure needs to be measured by installing a gauge pressure transducer at the inlet, as shown in Fig 5. The net head is given by

$$H = \left[z_1' + \frac{p_1'}{\rho g} + \frac{v_1^2}{2g} \right] - (z_2)$$

$$= \frac{p_1'}{\rho g} + z + \frac{v_1^2}{2g}$$

where,

z_1' is the elevation of the pressure transducer in m,

p_1' is the reading of the pressure transducer in Pa,

v_1 is the velocity of water at the inlet to turbine in m/s,

z_2 is mean elevation of the points at which the water jets from nozzles strike the buckets, and

$$z = z_1' - z_2$$

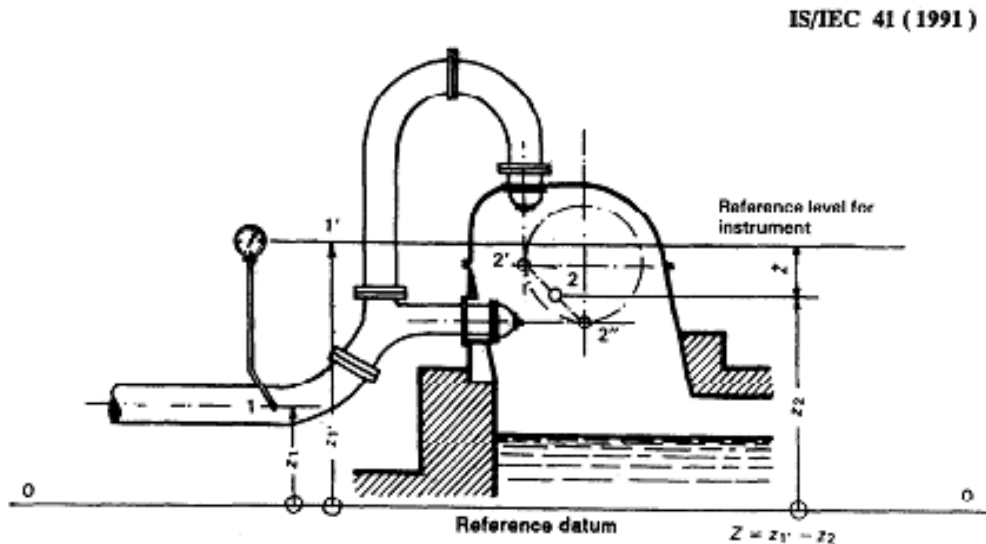

Fig. 5: Horizontal-axis Pelton turbine, pressure transducer at inlet

Source: IEC-60041

1: Inlet (Centre line of penstock)

1': Reference level for pressure gauge at inlet

2: Mean location of the points at which water jets strike the buckets

7.11 Measurement of Electrical Power Output

A reference digital wattmeter with an accuracy class of 0.2 or better is connected in parallel with the panel wattmeter of the generator. The accuracy class of the generator CTs and VTs should be at least 0.5, preferably 0.2. A test terminal block (TTB) or sliding-link type terminals, if provided in the metering panel, would facilitate connecting the reference

wattmeter without shutting down the machine. The electrical power output of the generator is calculated by multiplying the reference wattmeter reading with CT ratio and VT ratio. It is recommended that the wattmeter be used in integrating mode so that the average electrical power output of the machine over the duration of the efficiency test at a given load could be obtained directly by dividing the integrated-energy reading with the time-duration reading.

7.12 Calculation of Unit Efficiency (Discharge Head Method)

7.12.1 Calculation Procedure

The electrical power output, P_e , of the generator in watts is given by

$$P_e = \frac{\text{Integrated energy in Wh}}{\text{Integration time in hours}} \times CTR \times VTR \quad (1)$$

The efficiency of the turbine-generator unit is given by

$$\eta = \frac{\text{Electrical power output of genertor } (P_e)}{\text{Hydraulic power input to turbine } (P_h)} \quad (2)$$

Hydraulic power input to the turbine in watts is given by

$$P_h = \rho g H Q \quad (3)$$

where

- ρ = actual density of water in the turbine in kg/m^3
- g = actual acceleration due to gravity of earth at the site in m/s^2
- H = net head in m
- Q = discharge rate in m^3/s

The value of H is determined using one of the equations given in Sections 7.10.1 to 7.10.5 depending on the given situation (Cases 1 to 5).

The above equations are used for calculating the unit efficiency at different loads from the instrument readings taken during the efficiency test.

7.12.2 Case Study of SHP Station with Kaplan Turbine

(a) Power Station Data

- Station Capacity: 5x4.8 MW
- Turbine Type: Horizontal-shaft, fully-controlled Kaplan
- Turbine Ratings: 7.50 m, 79.2 m^3/s , 158 rpm
- Generator Type: Horizontal-shaft, synchronous
- Generator Ratings: 4.8 MW, 0.85 pf, 5.65 MVA, 11 kV, 50 Hz, 750 rpm
- Speed Increaser: 158 rpm/ 750 rpm gear box

(b) Unit Efficiency Test Data

Generating Unit Tested: Unit-4

Test Points: 60%, 80%, 100% and 105% of rated load

Method of Headrace Water Level Measurement: Two ultrasonic level sensors

Method of Tailrace Water Level Measurement: Two ultrasonic level sensors

Method of Discharge Measurement: Propeller current meters at stop-log opening at the intake

Method of Electrical Power Measurement: Digital wattmeter in integration mode

(c) Averages of the Readings Taken are shown in table 1 below:

Table 1: Averages of the Readings Taken for Efficiency Test of Kaplan Turbine

| <i>Load</i> <i>(% of rated value)</i> | <i>60%</i> | <i>80%</i> | <i>100%</i> | <i>105%</i> |
|--|-------------------|-------------------|--------------------|--------------------|
| Headrace Water Level - Right Side (m above MSL) | 18.883 | 18.861 | 18.807 | 18.828 |
| Headrace Water Level - Left Side (m above MSL) | 18.874 | 18.846 | 18.799 | 18.820 |
| Mean Headrace Water Level (m above MSL) | 18.879 | 18.854 | 18.804 | 18.824 |
| Tailrace Water Level - Right Side (m above MSL) | 9.053 | 9.024 | 9.043 | 9.059 |
| Tailrace Water Level - Left Side (m above MSL) | 9.070 | 9.039 | 9.051 | 9.072 |
| Mean Tailrace Water Level (m above MSL) | 9.062 | 9.032 | 9.047 | 9.066 |
| Discharge (m ³ /s) | 36.686 | 46.687 | 59.473 | 62.042 |
| Energy Reading (Wh) | 17.956 | 23.951 | 60.326 | 31.304 |
| Time of Integration (hour : min : sec) | 00:15:00 | 00:15:00 | 00:30:00 | 00:15:00 |

(d) Unit Efficiency Calculations (Table 2)

CT Ratio = 400A/1A

VT Ratio = 11 kV/110 V

Actual density of water, $\rho = 996.2 \text{ kg/m}^3$

Actual acceleration due to gravity, $g = 9.783 \text{ m/s}^2$

Head loss in trash rack = 0.1 m (assessed)

Head loss in intake duct = $0.5 \times V_d^2 / 2g$ (assessed)

Table 2: Unit Efficiency Calculations for Kaplan Turbine

| <i>Load</i> <i>(% of rated value)</i> | <i>60%</i> | <i>80%</i> | <i>100%</i> | <i>105%</i> |
|--|----------------------|----------------------|----------------------|----------------------|
| Electrical Power Output from eq. (1) (kW) | 2872.9 | 3832.2 | 4826.0 | 5008.6 |
| Net Head calculated as per Section 7.10.3 (m) | 9.487 | 9.642 | 9.445 | 9.528 |
| Hydraulic Power Input from eq. (3) (kW) | 3391.931 | 4387.097 | 5474.291 | 5761.089 |
| <i>Unit Efficiency from eq. (2)</i> | <i>84.70%</i> | <i>87.35%</i> | <i>88.16%</i> | <i>86.94%</i> |

(e) Load-Efficiency Curve of the Generating Unit with Kaplan Turbine

Load-Efficiency Curve of the Generating Unit with Kaplan Turbine is shown in Fig 6 Below:

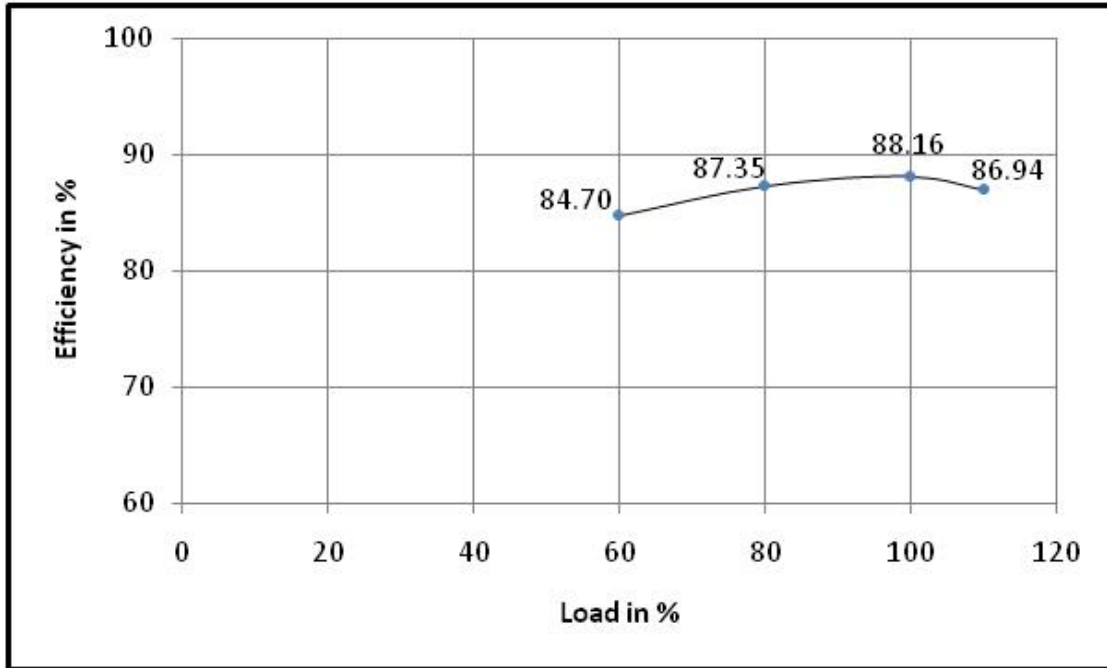

Fig. 6 : Load-Efficiency Curve of the Generating Unit with Kaplan Turbine

7.12.3 Case Study of SHP Station with Francis Turbine

(a) Power Station Data

Station Capacity: 3x2.4 MW
Turbine Type: Horizontal-shaft, Francis
Turbine Ratings: 54.5 m, 5.5 m³/s, 600 rpm
Generator Type: Horizontal-shaft, synchronous
Generator Ratings: 2.4 MW, 0.8 pf, 3 MVA, 3.3 kV, 50 Hz, 600 rpm

(b) Unit Efficiency Test Data

Generating Unit Tested: Unit-2
Test Points: 60%, 80%, 100% and 110% of rated load
Method of Intake Pressure Head Measurement: Electronic pressure transducer
Method of Tailrace Water Level Measurement: Two ultrasonic level sensors
Method of Discharge Measurement: UTTF on penstock of unit-2
Method of Electrical Power Measurement: Digital wattmeter in integration mode

(c) Averages of the Readings Taken are shown in table 3 below:

Table 3: Averages of the Readings Taken for Francis Turbine

| Load (% of rated value) | 60% | 80% | 100% | 110% |
|---|------------|------------|-------------|-------------|
| Intake Pressure (kg/cm ²) | 6.023 | 5.946 | 5.987 | 5.998 |
| Tailrace Water Level - Right Side (m above MSL) | 1047.725 | 1047.781 | 1047.868 | 1047.935 |
| Tailrace Water Level - Left Side (m above MSL) | 1047.740 | 1047.847 | 1047.872 | 1047.940 |
| Mean Tailrace Water Level (m above MSL) | 1047.732 | 1047.814 | 1047.870 | 1047.937 |
| Discharge (m ³ /s) | 3.5513 | 4.1707 | 5.2028 | 5.6281 |
| Energy Reading (Wh) | 17.515 | 22.387 | 59.131 | 31.697 |
| Time of Integration (hour : min : sec) | 00:15:00 | 00:15:00 | 00:30:00 | 00:15:00 |

(d) Unit Efficiency Calculations (Table 4)

CT Ratio = 700A/1A

VT Ratio = 3.3 kV/110 V

Actual density of water, $\rho = 999.8 \text{ kg/m}^3$

Actual acceleration due to gravity, $g = 9.790 \text{ m/s}^2$

Table 4: Unit Efficiency Calculations for Francis Turbine

| Load (% of rated value) | 60% | 80% | 100% | 110% |
|---|---------------|---------------|---------------|---------------|
| Electrical Power Output from eq. (1) (kW) | 1471.260 | 1880.508 | 2483.502 | 2662.548 |
| Net Head calculated as per Sections 7.10.2 & 7.10.3 (m) | 57.621 | 56.829 | 57.305 | 57.406 |
| Hydraulic Power Input from eq. (3) (kW) | 2002.919 | 2319.937 | 2918.274 | 3162.392 |
| Unit Efficiency from eq. (2) | 73.46% | 81.06% | 85.10% | 84.19% |

(b) Load-Efficiency Curve of the Generating Unit with Francis Turbine

Load-Efficiency Curve of the Generating Unit with Francis Turbine is shown in Fig 7 below:

7.12.4 Case Study of SHP Station with Pelton Turbine

(a) Power Station Data

Station Capacity: 2x2.0 MW

Turbine Type: Horizontal-shaft, two-jet Pelton

Turbine Ratings: 198 m, 1.198 m³/s, 500 rpm

Generator Type: Horizontal-shaft, synchronous

Generator Ratings: 2.0 MW, 0.9 pf, 2.222 MVA, 3.3 kV, 50 Hz, 500 rpm

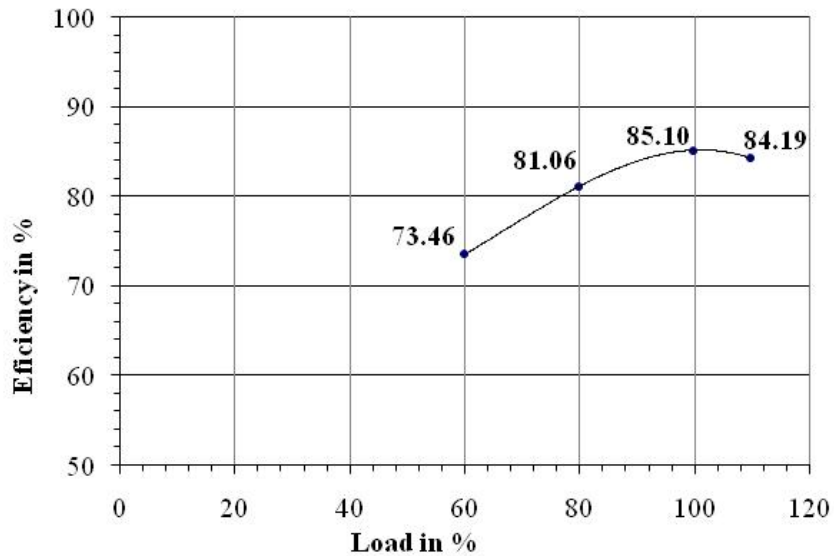

Fig. 7: Load-Efficiency Curve of the Generating Unit with Francis Turbine

(b) Unit Efficiency Test Data

Generating Unit Tested: Unit-1

Test Points: 60%, 80%, 100% and 110% of rated load

Method of Intake Pressure Head Measurement: Electronic pressure transducer

Method of Discharge Measurement: UTTF on penstock of unit-1

Method of Electrical Power Measurement: Digital wattmeter in integration mode

(c) Averages of the Readings Taken and shown in table 5 below:

Table 5: Averages of the Readings Taken for Pelton Turbine

| <i>Load (% of rated value)</i> | <i>60%</i> | <i>80%</i> | <i>100%</i> | <i>110%</i> |
|--|------------|------------|-------------|-------------|
| Intake Pressure (kg/cm ²) | 20.623 | 20.469 | 20.176 | 20.078 |
| Discharge (m ³ /s) | 0.7680 | 0.9987 | 1.2250 | 1.3423 |
| Energy Reading (Wh) | 20.110 | 26.662 | 65.373 | 35.212 |
| Time of Integration (hour : min : sec) | 00:15:00 | 00:15:00 | 00:30:00 | 00:15:00 |

(d) Unit Efficiency Calculations (Table 6)

CT Ratio: 500A/1A

VT Ratio: 3.3 kV/110 V

Actual density of water, ρ : 1000.5 kg/m³

Actual acceleration due to gravity, g : 9.791 m/s²

Height of the pressure transducer above mean elevation of the points at which the water jets from nozzles strike the buckets: 1.814 m

Table 6: Unit Efficiency Calculations for Pelton turbine

| Load (% of rated value) | 60% | 80% | 100% | 110% |
|---|---------------|---------------|---------------|---------------|
| Electrical Power Output from eq. (1) (kW) | 1206.600 | 1599.720 | 1961.190 | 2112.720 |
| Net Head calculated as per Section 7.10.5 (m) | 208.141 | 206.749 | 203.990 | 203.115 |
| Hydraulic Power Input from eq. (3) (kW) | 1565.898 | 2022.655 | 2447.874 | 2670.762 |
| Unit Efficiency from eq. (2) | 77.05% | 79.09% | 80.12% | 79.11% |

(e) Load-Efficiency Curve of the Generating Unit with Pelton turbine

Load-Efficiency Curve of the Generating Unit with Pelton turbine is shown in Fig 8 below:

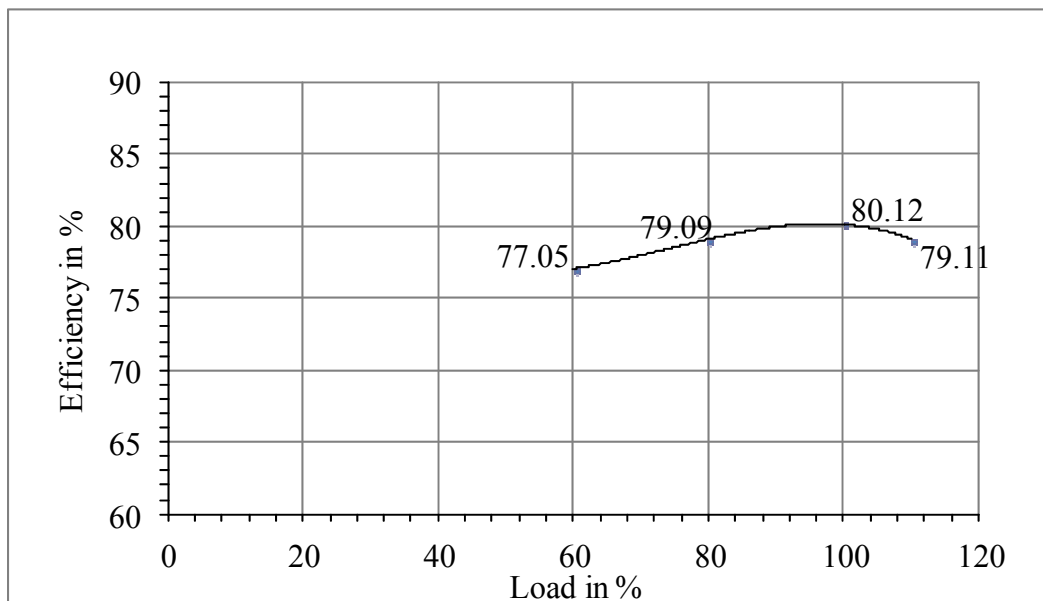

Fig. 8: Load-Efficiency Curve of the Generating Unit with Pelton turbine

7.13 Calculation of Weighted Efficiency

The weighted efficiency is the effective efficiency of a generating unit actually realized in operation for the given flow-duration curve. The weighting factors (K_1, K_2, \dots, K_n) for the generating unit for rated and part loads (L_1, L_2, \dots, L_n) are calculated from the flow-duration curve of the power station. These weighting factors along with the values of unit efficiency in per unit ($\eta_1, \eta_2, \dots, \eta_n$) at the respective loads as obtained from the unit efficiency test are used to calculate the weighted efficiency of the generating unit from the following formula:

Weighted efficiency of the generating unit in percent

$$= \left((K_{\downarrow 1} \times (\downarrow 1)) + (K_{\downarrow 2} \times (\downarrow 2)) + \dots + (K_{\downarrow n} \times (\downarrow n)) \right) / \left((K_{\downarrow 1} + K_{\downarrow 2}) + \dots + (K_{\downarrow n}) \right) 100$$

7.14 Index Test

The test involves measurements of relative discharge and relative efficiency as opposed to the measurement of their absolute values for unit efficiency test. The methods used for measuring the relative discharge are secondary methods. Relative values are derived from an index value, which is an arbitrary scaled value, by expressing them as a proportion of the index value at an agreed or defined condition.

As per the IEC Standard 60041, the results of the index test should *not* be used for any contractual consequences, except where both the parties agree. The standard suggests that the index test may be conducted for any of the following purposes:

- (i) To determine the relative variation in the unit efficiency with load or gate/valve opening.
- (ii) To determine the correct relationship between runner blade angle and guide vane opening in the case of a double regulated machine.
- (iii) To provide additional test data during the unit efficiency test.

IEC-60041 recommends that the relative discharge measurement required for the index test can be made by one of the following methods:

- (i) Measurement of pressure difference between suitably located taps on the turbine spiral case (Winter-Kennedy method).
- (ii) Measurement of pressure difference between suitably located taps in tubular turbines.
- (iii) Measurement of pressure difference between suitably located taps on a bend or taper section of the penstock.
- (iv) Single-path ultrasonic transit-time flowmeter.
- (v) Measurement of needle stroke on pelton turbines.
- (i) Measurement by means of a single current meter

As per the IEC Standard 62006, one of the methods shown in Table 7 may be used, and the discharge may be assumed to be nearly proportional to the square root of the differential pressure.

Table 7: Methods for measurements differential pressure

| Device | Usual differential pressure (Δp) at maximum load |
|---|--|
| <i>Differential Pressure Methods</i> | |
| Full spiral case (Winter-Kennedy) | 10 to 40 kPa |
| Tubular turbine (Bulb, pit turbine) | 10 to 30 kPa |
| Convergent pipe (Conical pipe) | 10 to 40 kPa |
| Stagnation probe | 15 to 60 kPa |
| <i>Flow Indicators</i> | |
| Simplified flow measuring methods | - |
| Needle stroke on Pelton and Turgo turbines | - |

8.0 METHODOLOGY OF PERFORMANCE EVALUATION

The performance evaluation of a SHP station is carried out in five steps as follows:

Step I: Station and Generation Data Compilation

All important data and drawings of the SHP station, needed for the inspection, functional/operational checks and testing of the power station, are obtained from the power station owner. A format for obtaining power station data from the station owner is recommended in Annexure I. Information showing conformity of the major plant equipment and components to the Indian/International standards, is an important part of the station data. The owner can collect this data from the design consultant, contractor and equipment manufacturer concerned as well as his own records.

In addition, the daily generation data for the period starting with the date of commissioning and the month-wise projected generation as per DPR are also obtained from the owner in the format recommended in Annexure II.

Step II: Planning

Based on the data and drawings obtained, the test agency may then plan inspection, checks and tests that need to be carried out, and prepare a complete schedule for the same. Constraints like non-availability of provisions for certain difficult tests, like index test and unit efficiency test, and inadequacy of water etc. can adversely affect the accuracy and timing of tests. Where necessary, the site may be visited in advance for ascertaining the best possible methods of measurements and recommending to the station owner any provisions that should be made to facilitate these measurements.

Step III: Instrument Checking / Recalibration

The test instruments may be checked /recalibrated before taking them to the site or at the site, as necessary, to ensure they are fit for conducting the tests at site.

Step IV: Inspection, Checks and Measurements/Tests at Site

Inspection, functional checks and measurements/tests (as detailed in earlier sections) are then conducted at the site as per the schedule. As far as possible, the *vital parameter* like discharge should be measured by two independent methods so that the exercise does not go in vain in case one method fails to give dependable results.

Step V: Test Report Preparation

Finally, a test report is prepared. For each major test or measurement, the report should mention the method and instrument used along with the test results. For critical measurements, an assessment of the uncertainties of measurement should be made. Remarks and conclusions on the test results along with recommendations may be given for the benefit of the end users of the report.

9.0 PROVISIONS TO FACILITATE PERFORMANCE TESTING

The IEC: 60041 and other standards, relevant to the testing of hydropower plant equipment, emphasize on the accuracy of field test, specially the measurements meant for

evaluating the efficiency of generating units. These standards lay down certain requirements in terms of some provisions necessary in the plant equipment, electrical and mechanical works and civil works. It is necessary for the SHP developers, equipment manufacturers, designers and contractors to make appropriate provisions for conducting the performance test to achieve the following:

- (a) To ensure conformity of the tests to the standards.
- (b) To achieve high accuracies and minimize uncertainties of measurements.
- (c) To reduce effort, time and cost of testing.
- (d) To reduce the number and duration of shutdowns needed during testing.

Longer shut-downs of the power station result in loss of generation, which can be largely avoided if appropriate provisions for conducting performance tests are available. Lack of certain provisions can increase uncertainties of measurements considerably and, in some extreme cases, even make some tests impossible. On the other hand, well planned provisions in the plant equipment and power station not only facilitate the testing but also make the job of operation & maintenance engineers of the power station simpler and systematic.

This Section elaborates on such provisions and gives guidelines on how to provide them in the power station /plant equipment in conformity with the relevant International/Indian standards. For any clarification or further details, one can refer to the relevant standard.

9.1 General Guidelines

- (a) Permanent benchmarks for reference should be provided at the power house building, tailrace channel and intake.
- (b) Centre-line for reference should be marked on penstock near the turbine intake, butterfly valve, casing of horizontal-shaft turbine and other similar components.
- (c) Good drawings, preferably soft copies, should be preserved for reference and be made available during performance testing.
- (d) Records of commissioning test results should be preserved for reference and be made available during performance testing.
- (e) Records of any problems experienced during operation and maintenance should be preserved and made available at site to the performance test team.
- (f) All requirements of and necessary provisions on various equipments mentioned in Sections 9.2 to 9.9 below should be included, as and where applicable, in the tender technical specifications document at the time of procurement of these equipments.
- (g) All requirements of and necessary provisions in the civil & hydraulic structures mentioned in Sections 9.2 to 9.8 below should be included, as and where applicable, in the tender technical specifications document at the time of awarding construction contracts.

9.2 Provisions for Pressure Measurement

Reference: IEC-60041 (1991), Clause 11.4

9.2.1 Choice of Pressure Measuring Section

- (a) The location of the measuring section should be such that there is a minimum of disturbance to the flow at that location.

- (b) Sections where the velocity pattern is distorted by the presence of an elbow or valve or other flow disturbances outside of the hydraulic machine should be avoided.
- (c) The plane of the measuring section shall be normal to the average direction of flow.
- (d) Area of the measuring section, which is required for computing the mean water velocity, should be readily measurable.
- (e) The measuring section should preferably be arranged in a straight conduit section (which may also be slightly convergent or divergent) extending at least three diameters upstream and two diameters downstream from the measuring section.
- (f) The measuring section should be free from any water extraction or injection active during the test.
- (g) Closed branches of the conduit, if any, shall be more than five times their diameter away from the measuring section.

9.2.2 Number and Locations of Pressure Taps

- (a) Generally, for any form of section, at least two pairs of opposite pressure taps (i.e. total of four taps) shall be used.
- (b) With favourable conditions, the number of taps can be reduced by mutual agreement.
- (c) In the case of circular sections the four pressure taps shall be arranged on two diameters at right angles to each other.
- (d) The taps shall not be located at or near the highest point of the measuring section in order to avoid air pockets.
- (e) The taps shall also not be located near the lowest point because of the risk of dirt obstructing the taps.
- (f) If taps have to be arranged at the top or bottom of a section, special care has to be observed to avoid disturbances due to air or dirt.
- (g) In the case of non-circular (in most cases rectangular) sections, the taps shall not be located near the corners.
- (h) Individual mean pressure measurements around the measuring section should not differ from one another by more than 0.5% of the specific hydraulic energy of the machine or 20% of the specific kinetic energy calculated from the mean velocity in the measuring section. If this requirement is not fulfilled and if it is not possible to correct the faulty tap, a mutual agreement should be reached to eliminate the faulty tap or to select another location or to accept this deviation.

9.2.3 The Pressure Taps

- (a) Pressure taps should be located in inserts of non-corroding material; Fig 9 shows two typical inserts at (a) and (b).
- (b) Inserts should be installed flush with the inner wall of conduit.
- (c) The cylindrical bore of the pressure tap shall be 3 mm to 6 mm in diameter and have a minimum length of at least twice the diameter.
- (d) The bore should be perpendicular to the conduit wall and free of all burrs or irregularities which could cause local disturbance.
- (e) The edges of the openings should preferably be provided with a radius $r = d/4$ smoothly joining the flow passage ('d' being the diameter of the bore of the pressure tap, as shown in Fig 9). The purpose of this rounding is to eliminate any possible burrs.

- (f) The surface of the conduit shall be smooth and parallel with the flow in the vicinity of the bore for at least 300 mm upstream and 100 mm downstream.
- (g) In concrete passageways, the pressure taps shall be at the centre of a stainless steel or bronze plate at least 300 mm in diameter flush with the surrounding concrete.

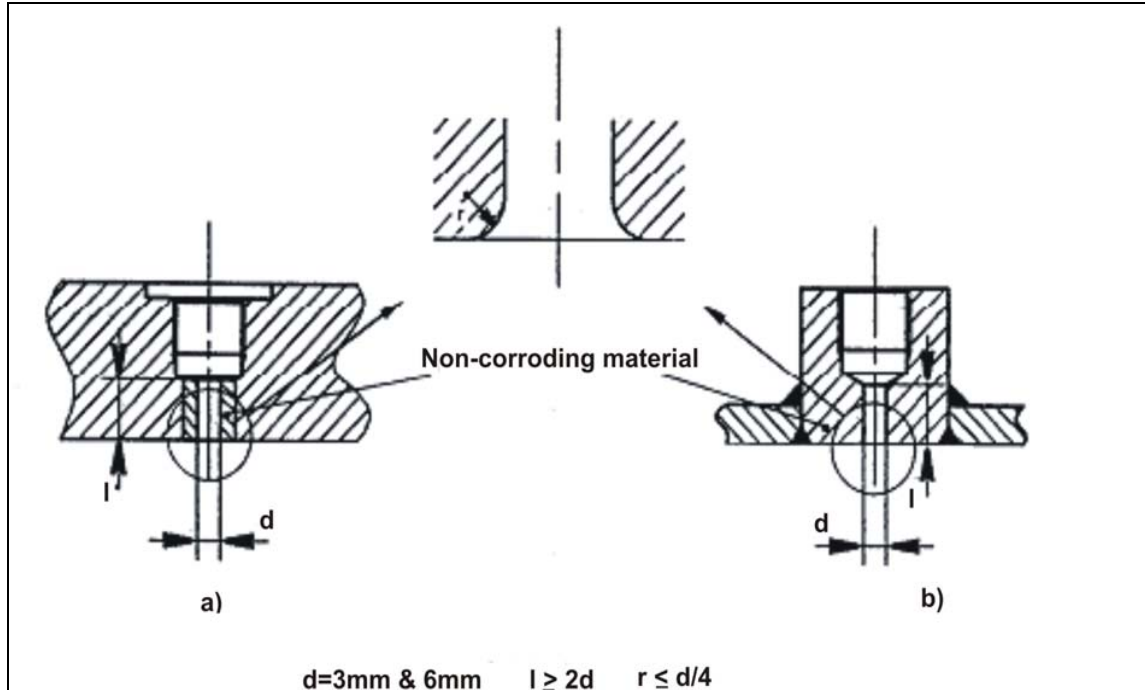

Fig. 9: Example of pressure taps
Source: IEC-60041 (1991)

9.2.4 Gauge Piping

- (a) Pressure taps shall be manifolded either by connecting them to a box-type manifold (Fig 10) or by connecting them through a ring-type manifold (Fig 11).
- (b) Each tap shall have a separate valve so that pressure at the taps can be read individually.
- (c) The diameter of the connecting piping shall be at least twice that of the tap, not less than 8 mm and not more than 20 mm.
- (d) The diameter of the manifold shall be at least three times the diameter of the tap.
- (e) Special precautions shall be taken when pipes are embedded in concrete.
- (f) Connection pipes should, if possible, be of equal length, slope upward to the pressure gauge with no intermediate high spots where air may be trapped.
- (g) A valve shall be provided at the highest point for flushing out (venting) air, as shown in Fig 10 and Fig 11.
- (h) Transparent plastic tubing is available for a wide pressure range and should be preferred as it is helpful in detecting the presence of air bubbles.
- (i) No leaks shall be permitted in the gauge connection.

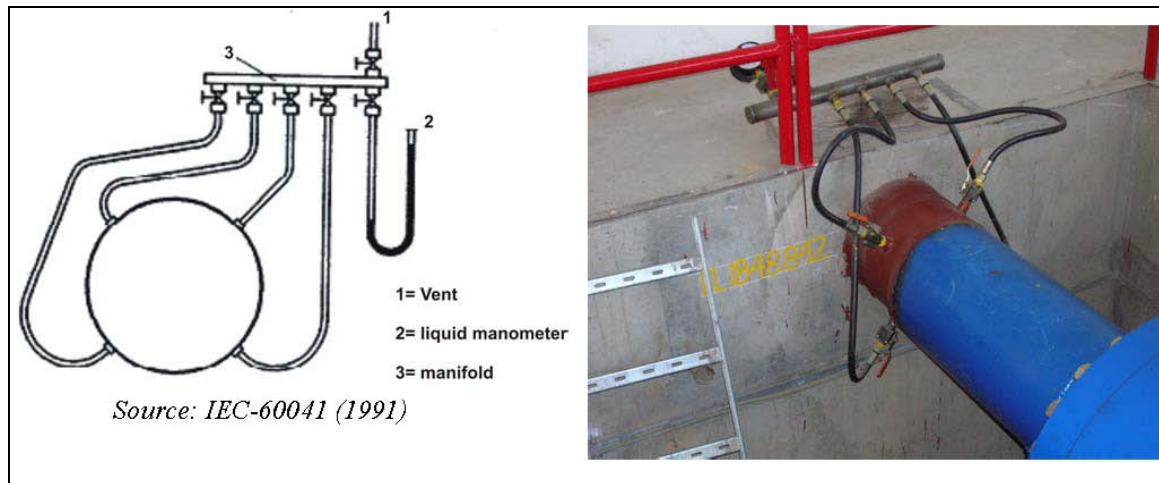

Fig. 10 : Pressure taps connected through separate connecting pips to box-type manifold

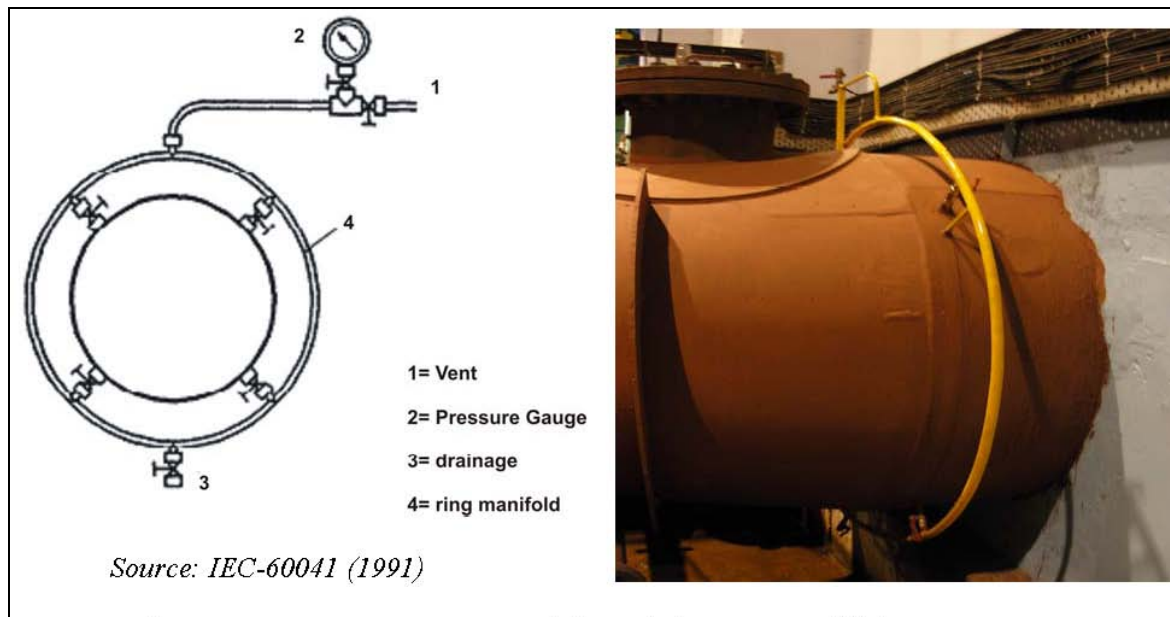

Fig. 11 : Pressure taps connected through ring-type manifold to pressure gauge

9.2.5 Damping Devices

- (a) When the pressure to be measured is fluctuating, (i.e. changing at a high frequency), it may be difficult to obtain correct readings on a pressure gauge. In order to improve such conditions, suitable damping shall be provided.
- (b) Damping requires special care, because a proper damping device depending on viscous resistance should be fully symmetrical with equal resistance to flow in both directions.
- (c) A capillary tube with a 1 mm bore and a suitable length (e.g. 50 mm to 150 mm) is recommended for this purpose because it provides linear damping of irregular pressing pulsations.

- (d) Additional damping may be obtained from an air or surge chamber connected to the pressure line ahead of the gauge.
- (e) Using an orifice plate is not recommended because it may introduce an error due to nonlinear damping.
- (f) A valved bypass around any damping device should be provided and kept open except for the short time during which readings are taken.
- (g) Bending or pinching the connecting pipes or inserting any non-symmetrical throttling device is not permitted.

9.3 Provisions for Free Water Level Measurement

Reference: IEC-60041 (1991), Clause 11.5

9.3.1 Choice of Water Level Measuring Sections

- (a) The flow in the measuring section shall be steady and free of disturbances.
- (b) Sections where the flow velocity is influenced by an elbow or by other irregularities should be avoided.
- (c) The area at the measuring sections is used to determine the mean water velocity and hence it shall be accurately defined and readily measurable.

9.3.2 Number of Measuring Points in a Measuring Section

- (a) Measurement of free water levels shall be obtained for at least two points in every measuring section or in each passage of a multiple passage measuring section.
- (b) The average of the readings is to be taken as the free water level.

9.3.3 Measuring Wells and Stilling Boxes

- (a) If the free surface is not accessible or not sufficiently calm, measuring wells with an area of about 0.1 m^2 which permit accurate and convenient measurements shall be provided (Fig 12).
- (b) All connections shall be normal to the wall of the measuring section and should preferably be covered with smooth perforated plates (perforations of 5 mm to 10 mm diameter).
- (c) Such cover plates should be flush with the wall of the measuring section to cruminate any local disturbances.
- (d) The connection between the measuring section and well should have a passage area of at least 0.01 m^2 .
- (e) The total area of perforation should be in the under of 25% of the passage area.
- (f) It is recommended that at least two measuring wells be provided at each measuring section on opposite sides of the canal/channel.

9.4 Provisions for Absolute-Discharge Measurement in General

Reference: IEC-60041 (1991), Clauses 10.1, 10.1.1 and 15.1.3.

- (a) The measurement of discharge in a hydroelectric or pumped storage plant can be performed with the desired accuracy only when the specific requirements of the chosen method are satisfied.

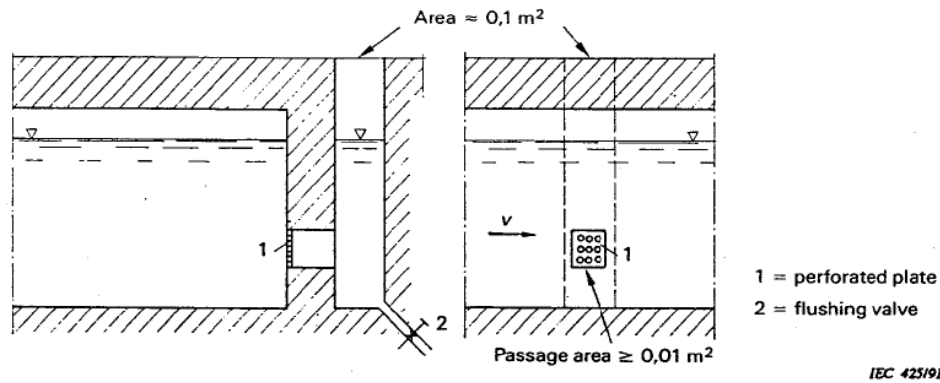

Fig. 12: Details of measuring well
Source: IEC-60041 (1991)

- (b) It is desirable to select the method(s) to be used for the performance testing at an early stage in the design of the plant because later provision may be expensive or even impracticable.
- (c) The discharge measurement for the unit efficiency test shall be made by an absolute method.
- (d) The absolute methods of discharge measurement recommended for use in the field are:
 - (i) Propeller current meters
 - (ii) Pitot tube
 - (iii) Pressure-time method
 - (iv) Tracer methods
 - (v) Weirs
 - (vi) Standardized differential pressure devices.
 - (vii) Volumetric gauging
 - (viii) Ultrasonic (or acoustic) method
- (e) It is recommended that provisions be made for two absolute methods of discharge measurement.
- (f) The choice of the method (s) for measuring discharge may be affected by
 - (i) Limitations imposed by the design of the plant;
 - (ii) Cost of installation and special equipment; and
 - (iii) Limitations imposed by the plant operating conditions.
- (g) It may be useful to resort to relative methods (index methods) of discharge measurement either to gain supplementary information or to make some measurements easier. This becomes particularly important if the primary method used shows excessive uncertainties or falls out in a certain operating range.

9.5 Provisions for Absolute-Discharge Measurement by Current Meter Method

Reference: IEC-60041 (1991), Clause 10.2

9.5.1 General Requirements

Reference: IEC-60041 (1991), Clause 10.2.1

- (a) The method may be used at a suitable measuring section in:
 - (i) A closed conduit or penstock

- (ii) An intake structure
- (iii) An upstream open channel (headrace)
- (iv) A downstream open channel (tailrace)
- (b) A number of propeller current-meters (PCMs) should be located at specified points in a suitable cross-section of an open channel or closed conduit.
- (c) Simultaneous measurements of local mean velocity with the meters should be integrated over the measuring section to obtain the discharge.
- (d) The water should be sufficiently clean, such that dissolved or suspended matter will not affect the accuracy of the meter readings during the test.
- (e) Integration techniques are used to compute the discharge assuming velocity distributions that closely approximate the known laws. Therefore, it is essential to select a measuring section that satisfies the following conditions:
 - (i) If open channel, it should be an artificial channel with uniform and well defined cross section and shall be straight for both upstream and downstream sides of the measuring section. Natural streams are excluded for tests under IEC Standard 60041.
 - (ii) If closed conduit, it should be nearly horizontal with smooth inner surface, uniform cross section and free from bends and discontinuities both upstream and downstream sides of the measuring section.

9.5.2 Number of Measuring Points

Reference: IEC-60041 (1991), Clause 10.2.2.2

- (a) The number of current-meters should be sufficient to ensure a satisfactory determination of the velocity profile over the whole measuring section. A single-point measurement is not permitted under the IEC Standard 60041.
- (b) If the conduit or channel is divided into several sections, measurements should be made simultaneously in all sections.
- (c) In a circular penstock, at least 13 measuring points should be used one of which should be the centre point of the section. The number of measuring points per radius, Z, excluding the centre point, may be determined from

$$4\sqrt{R} < Z < 5\sqrt{R}$$

where 'R' is the internal radius of the conduit in meters. For any given number of current-meters, it is preferable to increase the number of radii than to increase the number of current-meters per radius, but care should be taken to avoid excessive blocking. Centre blocking can be reduced by cantilevering the radial supporting arms from the conduit wall. If this is done, only a single arm need extend to the centre of the conduit. Measurements on more than 8 radii or at more than 8 points per radius, excluding the centre point, are not recommended.

- (d) In a rectangular or trapezoidal section, at least 25 measuring points should be used. If the velocity distribution is likely to be non-uniform, the number of measuring points, Z, should be determined from

$$24\sqrt{A} < Z < 36\sqrt{A}$$

where 'A' is the area of the measuring section in square metres.

9.5.3 Type and Size of Current Meters

Reference: IEC-60041 (1991), Clause 10.2.2.3

- (a) Only propeller-type current meters should be used.

- (b) The current meters should fulfill the applicable requirements of ISO - 2537.
- (c) The propeller current meters shall be capable of withstanding the water pressure and the time of submergence without charge in the calibration.
- (d) Current-meter propellers should be of diameter not less than 100 mm except for measurement in the peripheral zone where propellers of diameter as small as 50 mm may be used.
- (e) The distance from the trailing edge of the propeller to the leading edge of the mounting rod shall be at least 150 mm.
- (f) The angle between the local velocity vector and the axis of the current-meter shall not exceed 5° . When larger angles are unavoidable, self-compensating propellers which measure directly the axial component of the velocity, shall be used.

9.5.4 Provisions for Measurement in Short Penstocks and Intake Structures

Reference: IEC-60041 (1991), Clause 10.2.4

- (a) A penstock is defined as short if the straight length is less than 25 diameters.
- (b) The main difficulty in measuring discharge in short penstocks and intake structures arises from the fact that the measuring section may be located in a short converging conduit with uneven and/or unstable velocity distributions as well as oblique flow with respect to the current-meters.
- (c) To remedy these difficulties in relation to the intake structure, a temporary bell-mouth nozzle (see Fig 13) may be installed at the entrance to the intake structure achieving a straight and parallel flow. The flow through the modified intake may change the performance of the machine, but this change is negligible.

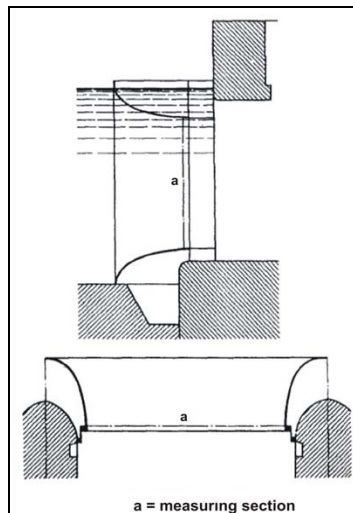

Fig. 13 : Temporary nozzle or bell-mouth placed in the intake of a low head turbine

Source: IEC-60041 (1991)

9.5.5 Provisions for Measurement in Open Channels

Reference: IEC-60041 (1991), Clause 10.2.5

- (a) The measuring section should have both width and depth greater than 0.80 m and at least eight times the diameter of the propeller.

- (b) The measuring section should be at least ten times its hydraulic radius (which is defined as the ratio of the wetted cross-sectional area to the wetted perimeter).
- (c) If necessary, the flow pattern at the measuring section may be improved by the installation of racks, rafts or submerged floor shown in Fig 14. Some of these devices are effective in suppressing surface waves also, which increases the accuracy of the depth-measurement.

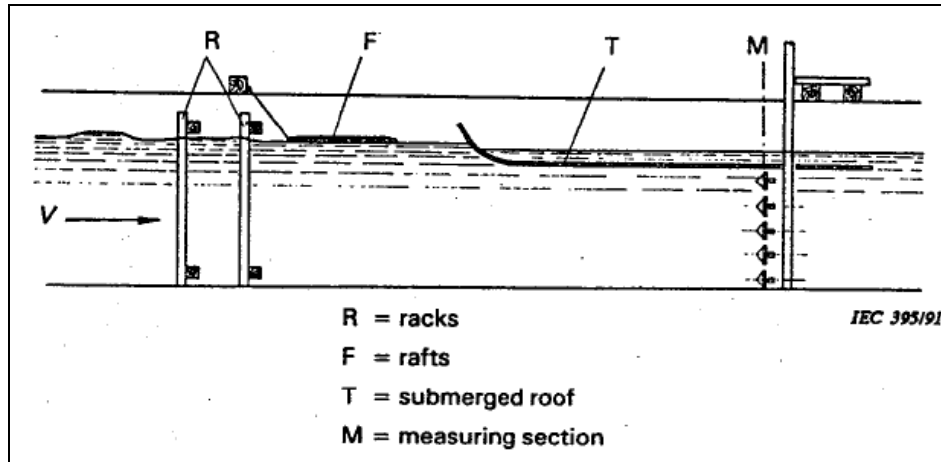

Fig. 14 : Means for stabilizing flow in an open channel

Source: IEC-60041 (1991)

- (d) There shall be a minimum of 25 measuring points located at the intersection of 5 horizontal and 5 vertical lines.
- (e) Measuring points should be closer to one another in the zones of steeper velocity gradient, i.e. near the walls, bottom and water surface.
- (f) Points should normally be spaced so that the difference in velocities between two adjacent points does not exceed 20% of the greater of the two velocities.
- (g) The minimum current-meter spacing should not be less than $(d + 30)$ mm, where 'd' is the outside diameter of the propeller in mm.
- (h) The distance from the axis of the nearest current-meter to any wetted surface should be within 0.75d minimum to 200 mm maximum.
- (i) The axis of the topmost current-meter in each row should be at least one propeller diameter below the free water surface.
- (j) All current-meters should be rigidly attached to the mounting rods with the propeller axes exactly perpendicular to the plane of the measuring section.
- (k) The stiffness of the mounting structures should be adequate to prevent current meter vibrations.
- (l) The structure should also offer a minimum stable drag and minimum interference with the current-meter operation.
- (m) The current-meters may be used as a stationary battery mounted on a number of parallel rods over the whole measuring section. Such an arrangement may produce a significant blockage effect in channels of small cross-section, and hence should not be used in small section channels.
- (n) As an alternative arrangement for mounting of current meters, a single vertical row of current meters mounted on a travelling winch (see Fig 15) or one or two horizontal rows of current meters mounted on a frame (see Fig 16 and Fig 17) may be moved to successive stations in the measuring cross-section. Since this requires steady flow

over a considerable length of time, any variations in the mean velocity should be monitored over the whole run by at least one fixed current-meter or by an index measurement of discharge. The water depth should also be monitored over the whole duration of each runs; variations in water depth should not exceed $\pm 1\%$ of the average value.

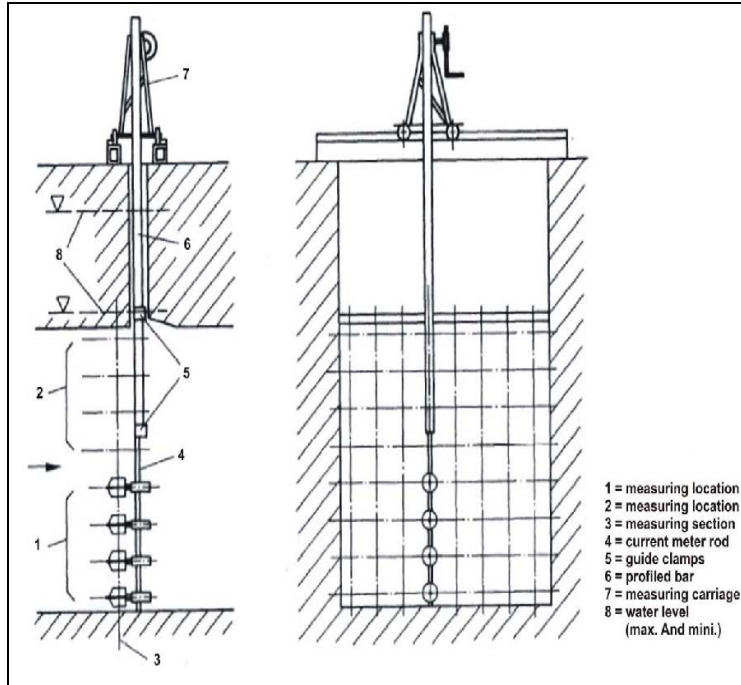

Fig. 15 : Single vertical row of current meters fixed on a travelling winch
Source: IEC-60041 (1991)

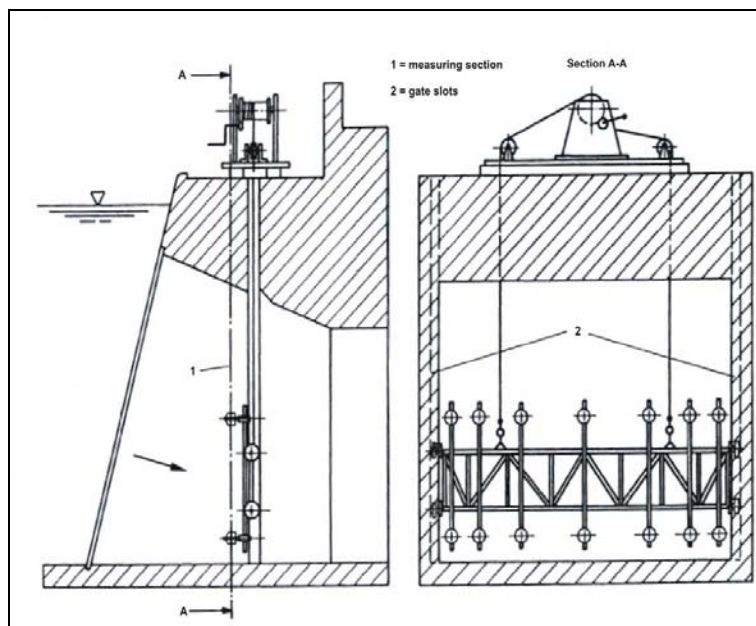

Fig. 16 : Frame supporting two rows of current meters moved up and down by a hoist
Source: IEC-60041 (1991)



Fig. 17 (a) : Frame lowered to submerge PCMs into water



Fig. 17 (b) : Frame raised to pull PCMs out of water

Fig 17: Frame supporting a single row of current meters moved up and down by a crane

9.6 Provisions for Absolute-Discharge Measurement using Weir

Reference: IEC-60041 (1991), Clause 10.6

9.6.1 Type of Weir

Reference: IEC-60041 (1991), Clause 10.6.1

(a) The discharge is measured by interposing a thin plate weir in a free surface flow, by

observing the head over the weir and by employing a unique functional relationship between the discharge and the head over the weir.

- (b) In order to have the best known relationship, only rectangular weirs without side contraction, sharp crested, with complete crest contraction, and free overflow should be used.

9.6.2 Design and Fixing of Weir Plate

Reference: IEC-60041 (1991), Clause 10.6.2

- (a) The plate constituting the weir should be smooth and plain, particularly on its upstream face.
- (b) This weir plate should preferably be made of a metal which can resist erosion and corrosion.
- (c) It should have sufficient thickness so that it is rigid.
- (d) It should be water tight and perpendicular to the walls and to the bottom of the channel.
- (e) The surface of the weir crest should be a horizontal, flat and smooth and should be perpendicular to the upstream face of the plate.
- (f) Intersection of the weir crest with the upstream face should be straight and form sharp edges, free from burrs or scratches.
- (g) Its edge width perpendicular to the upstream face should be within 1 mm to 2 mm.
- (h) If the weir plate is thicker than the allowable crest width, the downstream edge should be chamfered at a 45° angle (see Fig 18).
- (i) Complete aeration of the nappe should be secured.
- (j) The ventilation should be sufficient to keep the air underneath the nappe at approximately atmospheric pressure. The cross-sectional area of the ventilation holes should be at least 0.5% of the product of the length of the weir crest 'b' times the height, s_1 , of the weir above the water level in the downstream channel.

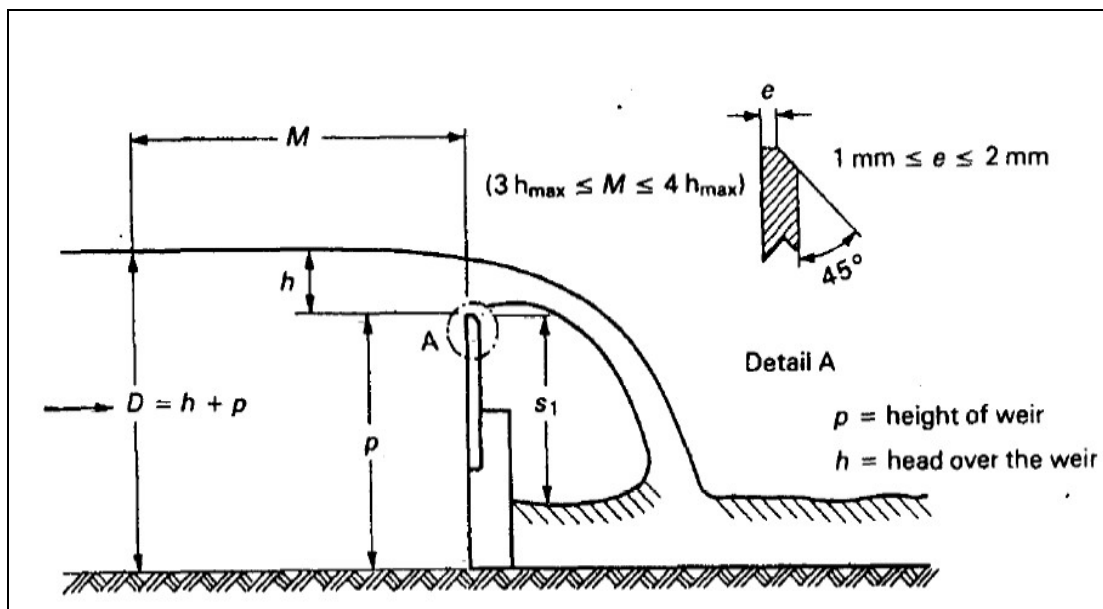

Fig. 18 : Sketch of a rectangular sharp-crested weir

Source: IEC-60041 (1991)

9.6.3 Location of Weir

Reference: IEC-60041 (1991), Clause 10.6.3

- (a) The weir is usually located on the low pressure side of the machine.
- (b) Care should be taken to ensure that smooth flow (free from eddies, surface disturbances or significant amounts of entrained air) exists in the approach channel.
- (c) There should be no loss or gain of water between the machine and the weir.
- (d) When the weir is located on the outlet side of the machine being tested, it should be far enough from the machine or the discharge conduit outlet to enable the water to release its air bubbles before reaching the weir.
- (e) Stilling screens and baffles should be used when necessary to give a uniform velocity distribution over the whole of the cross-section. Disturbed surface or undercurrents, or asymmetry of any kind, should be corrected by suitable screens.
- (f) The approach channel should be straight and of a uniform cross-section and with smooth walls for a length of at least 10 times the length of the weir crest.
- (g) If stilling screens or baffles are used, they should be located at distance upstream of the weir greater than this length.
- (h) Along this length, the bottom slope should be small (< 0.005).
- (i) A desilting sluice can be installed if required, but it should not disturb the regular flow of water along the upstream face of the weir.
- (j) The sides of the channel above the level of the crest of weir should extend without discontinuity at least $0.3 h_{\max}$ downstream of the plane of the weir.

9.6.4 Measurement of Head over Weir

Reference: IEC-60041 (1991), Clause 10.6.4

- (a) It should be easily possible to measure the head over weir 'h' upstream of the weir at a distance which shall be between three and four times the maximum head.
- (b) It should be easily possible to measure at a number of measuring points uniformly spaced across the weir channel.
- (c) The number of measuring points shall be as follows:

| <i>Length of crest 'b'</i> | <i>Number of measuring points</i> |
|------------------------------------|-----------------------------------|
| $b < 2\text{m}$ | 2 |
| $2\text{m} \leq b \leq 6\text{ m}$ | 3 |
| $b > 6\text{m}$ | 4 or more |

- (d) However this number may be reduced to a minimum of 2, where approach velocities are small and the velocity distribution is particularly regular.
- (e) Measurements of the head at each point of measurement should not differ by more than 0.5%. If they do, every endeavour should be made to this requirement by installing screens, baffles or rafts. The arithmetic mean of all the head measurements should be used for computing the discharge.
- (f) The head measurement devices should be placed in stilling wells at the sides of the approach channel, communicating through special pressure connections terminating in taps that are flush with the channel wall, 3 mm to 6 mm in diameter and at least twice the diameter in length.
- (g) The water in the stilling well should be purged from time to time to ensure that its temperature is within ± 2 C of that in the approach channel.

9.6.5 Discharge Formulae

Reference: Clauses 10.6.1, 10.6.5 and 10.6.6

- (a) The basic formula for calculating the discharge (due to Poleni) is :

$$Q = \frac{2}{3} C b \sqrt{2g} h^{3/2}$$

where

Q is the discharge

C is the discharge coefficient

b is the length of the weir crest (perpendicular to the flow)

g is the acceleration due to gravity

h is the measured upstream head over the weir

- (b) The accuracy of discharge measurements made with a rectangular thin-plate weir depends on the accuracy of the head and crest length measurements and on the accuracy of the discharge coefficient used. It is therefore desirable that, whenever possible, the weir should be calibrated under the existing conditions of installation and use.
- (c) If such a calibration is not carried out and no mutual agreement has been made by the parties for using one of the experimental formulae, the discharge should be computed by the following average formula:

$$Q = \left(0.4077 + 0.0497 \frac{h}{p} \right) b \sqrt{2g} h^{3/2}$$

The following dimensional restrictions apply:

$$b \geq 0.40 \text{ m}$$

$$p \geq 0.30 \text{ m}$$

$$0.06 \text{ m} \leq h \leq 0.80 \text{ m}$$

$$0.15 \leq h/p \leq 1.00$$

where p is the height of weir relative to the floor.

- (d) The use of the limiting values of more than one of the parameters given above at the same time should be avoided.

9.7 Provisions for Absolute-Discharge Measurement by Ultrasonic (Acoustic) Methods

Reference: IEC – 60041 (1991), Appendix J

9.7.1 General

The following ultrasonic discharge measuring methods/instruments, based on two altogether different principles, namely the transit-time and the Doppler effect, are now being used by the IIT Roorkee Test Group:

- Intrusion or wet-transducer ultrasonic transit-time flowmeter (WT- UTTF)
- Clamp-on or dry-transducer ultrasonic transit-time flowmeter (DT-UTTF)
- Horizontal-beam acoustic doppler current profiler (H - ADCP)
- Vertical-beam acoustic doppler current profiler (V - ADCP)

Technically, the method at (a) above is suitable for both steel-pipe penstocks and open channels, the method at (b) for steel-pipe penstocks only and the method at (c) for open

channels only. The method at (d) can be used in irregular-section channels, where most other methods of discharge measurement may be impracticable.

The IEC Standard 60041, which was issued in the year 1991, stipulates as follows: “Experience [till this time] with the acoustic [ultrasonic] methods of discharge measurement is limited. While the methods have yet to be accepted as primary methods, their application is permissible by mutual agreement or in conjunction with an established method of discharge measurement, in which case the latter method will prevail in the comparison with the guarantees”. Since then, however, a large number of instruments based on ultrasonic methods of discharge measurement have been developed and are widely used in several applications. The long experiences of turbine testing groups world over, including the one at IIT Roorkee, with different ultrasonic methods and instruments of discharge measurement have been very positive. Ultrasonic methods are now recognized as primary, versatile and reliable methods of absolute-discharge measurement for efficiency evaluation of generating units. The IEC standard IEC-62006, which has been issued in 2010, recognizes both strap-on or dry-transducer type and intrusion or wet-transducer type ultrasonic (acoustic) flowmeters as primary methods.

The intrusion or wet-transducer UTTF is the only ultrasonic method/instrument included in IEC-60041 and its use is described only with closed conduits. It has a very high accuracy potential, if applied properly and the site conditions are good. The clamp-on or dry-transducer type UTTF also can give a good accuracy under favourable conditions, while it is much cheaper and lot easier and faster to use as compared to its wet-transducer counterpart. The uncertainty of discharge measurement with dry-transducer UTTF in new SHP stations, based on the experience of the IIT Roorkee Test Team, ranges from 2.0-2.5%, against 1-2% for the wet-transducer UTTF as suggested in IEC-60041. The DT-UTTF also compares favourably in this regard with all other methods of discharge measurement. The WT-UTTF requires drilling of several holes in the penstock and hence not liked by power station owners.

The requirements and provisions for discharge measurement with WT-UTTF in penstocks as per IEC-60041 are described below. The requirements of discharge measurement with WT-UTTF in open channels, with DT-UTTF in conduits and with ADCPs in open channels, given in the following sections, are based on the same basic principles as well as on the experience of the IIT Roorkee Test Group.

9.7.2 Provisions for Discharge Measurement with WT-UTTF in Penstock

Reference: IEC – 60041 (1991), Appendix J

- (a) The transducers acting as the transmitter and receiver should be fixed in the conduit in such a way that signals are transmitted upstream and downstream at an angle Φ relative to the axis of the conduit (see Fig 19). The value of Φ should be between 45° and 75° . Therefore, necessary length of the penstock should be left un-embedded (exposed) at the time of construction to allow drilling of holes for transducers and fixing them.
- (b) In order to reduce the systematic uncertainty due to effects of transverse flow components, two acoustic planes A and B as shown in Fig 20 should be used.
- (c) If the velocity distribution were fully axi-symmetric, the average velocity measured along a single path located in an axial-plane could be assumed proportional to the mean flow velocity in the conduit. To take into account the actual velocity distribution

in practice it is necessary to install several pairs of transducers at opposite ends of a number of paths located in the measurement planes at angle Φ to the longitudinal axis of the conduit and distributed symmetrically about this axis, as shown in Fig 21.

- (d) The measuring section should be chosen as far as possible from any upstream disturbance, such as a bend, that could create asymmetry of the velocity distribution, swirl or large scale turbulence. Other factors that may produce transverse velocity components or distortion of the velocity profile are the flow conditions upstream of the intake, the shape of the intake, and the number of bends upstream of the measuring section, changes in upstream conduit diameter and the proximity of bends or changes in conduit diameter downstream.

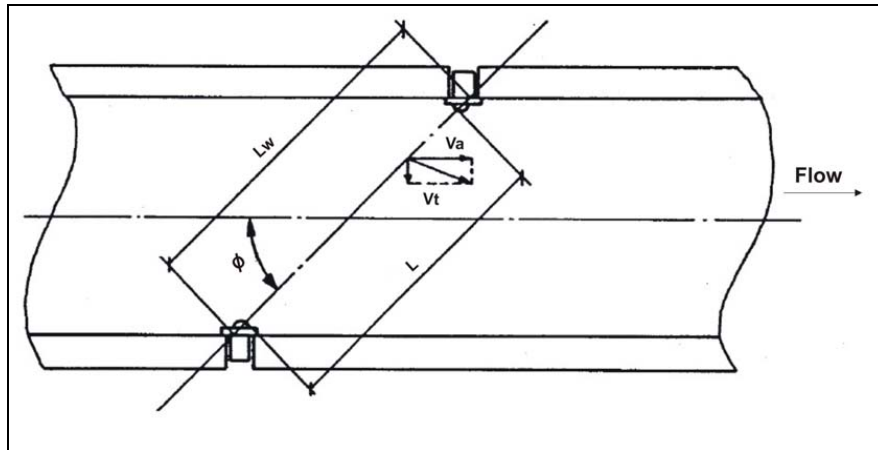

Fig. 19 : Locations of transducers for discharge measurement with UTMF
Source: IEC-60041 (1991)

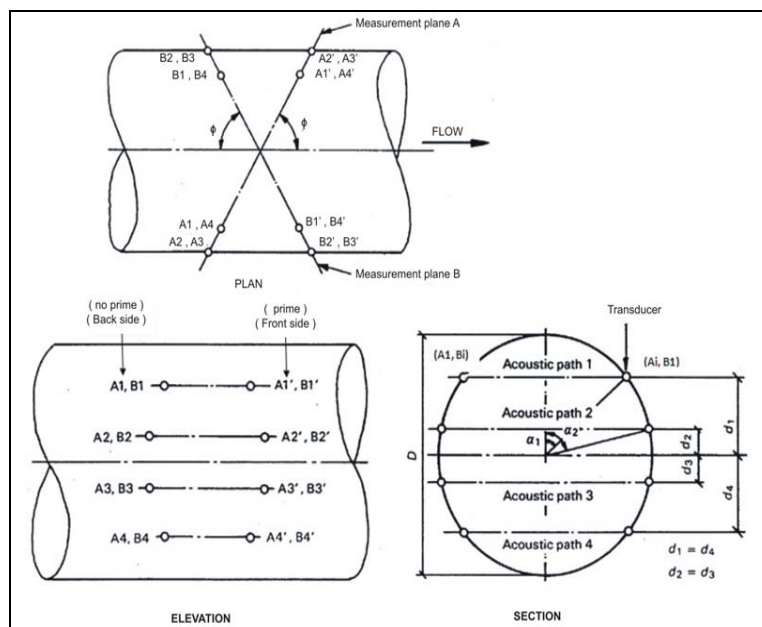

Fig. 20 : Typical arrangement of transducers in a circular conduit
Source: IEC-60041 (1991)

- (e) Measurement of discharge using a single path in one or two measuring planes is not permitted by the Standard.
- (f) If two acoustic planes with four paths each are used, then there should be a straight length of upstream conduit between the measuring section and any important irregularity of at least ten conduit diameters. Similarly, there should be a straight length of at least three conduit diameters between the measuring section and any important downstream irregularity.
- (g) A single acoustic plane with four paths located downstream of a straight length of twenty conduit diameters or more, providing a uniform flow distribution in the measuring section, is also acceptable.
- (h) It should be possible to empty the penstock to allow laying out of transducer locations, drilling of holes in the penstock, fixing the transducers and aligning them. (Although this process can be carried out in hot condition, that is, without stopping water flow in the penstock, the techniques used are very difficult and expensive).
- (i) Flow velocity and diameter of the conduit shall be large enough to permit an accurate determination of the difference in acoustic pulse transit times taking into account the accuracy of the timer. Measurements with flow velocities less than 1.5 m/s and diameters of conduits less than 0.8 m should be avoided.
- (j) Bubbles, sediment and acoustic noise may disrupt the operation of the acoustic flow measurement system and a measuring section involving any of them should be avoided.

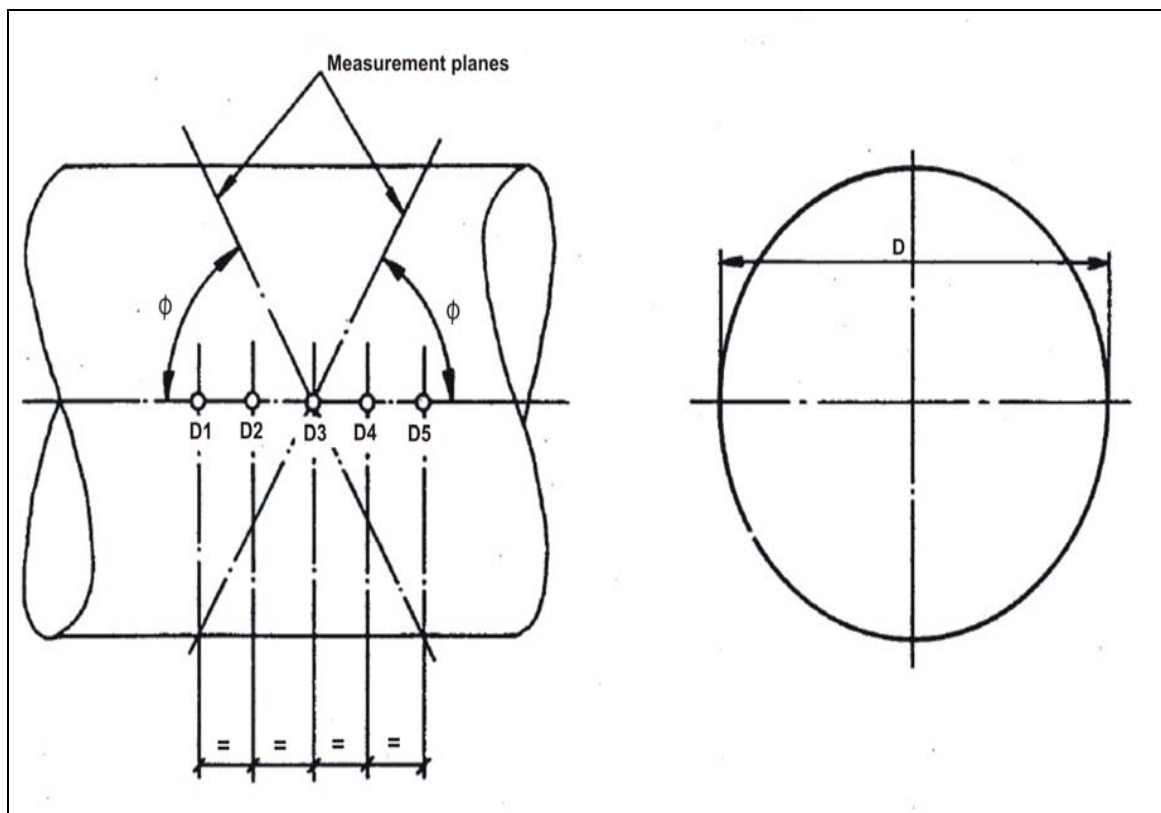

Fig. 21 : Locations for measurement of dimension D

Source: IEC-60041 (1991)

- (k) The layout of transducer locations and measurement of as-built dimensions should be done using accurate methods. For large conduits surveying techniques and for smaller conduits careful shop measurements can be used. In either case, the uncertainties of the as-built measurements should be accounted for in the error analysis.
- (l) Special care should be taken for conduits that do not have perfectly circular shape. A representative dimension D should be determined in the measuring section. At least five equally spaced measurements of D should be taken, including one at the centre of the measuring section and one at each end as illustrated in Fig 21. These measurements should be averaged to be representative of the conduit dimension in the measuring section.
- (m) Actual locations of transducers should be measured after drilling holes for the transducers, and any misplacement of transducer locations should be accounted for in the error analysis or by correction in the calculated discharge.

9.7.3 Provisions for Discharge Measurement with DT-UTTFF in Penstock

- (a) Adequate length of the penstock should be left un-embedded (exposed) to allow fixing of the transducers on the surface of the conduit (see Fig 22(a)).
- (b) As far as possible, the clamp-on or dry-transducer UTTFF should be used on a conduit in the reflection mode (see Fig 22(b)), so that average velocity over two paths is measured. Its use in transmission mode should be avoided because of the larger uncertainty of measurement associated with the single path.
- (c) The measuring section should be chosen as far as possible from any upstream disturbance, such as a bend, that could create asymmetry of the velocity distribution, swirl or large scale turbulence. Other factors that may produce transverse velocity components or distortion of the velocity profile are flow conditions upstream of the intake, the shape of the intake, the number of bends upstream of the measuring section, changes in upstream conduit diameter and the proximity of bends or changes in conduit diameter downstream.
- (d) There should be a straight length of upstream conduit between the measuring section and any important irregularity of at least ten conduit diameters. Similarly, there should be a straight length of at least three conduit diameters between the measuring section and any important downstream irregularity.
- (e) Flow velocity and diameter of the conduit should be large enough to permit an accurate determination of the difference in acoustic pulse transit-time taking into account the accuracy of the timer. Measurements with flow velocities less than 1.5 m/s and diameters of conduits less than 0.8 m should be avoided.
- (f) Bubbles, sediment and acoustic noise may disrupt the operation of the acoustic flow measurement system and measuring section involving any of them should be avoided.
- (g) Special care should be taken for conduits that do not have perfectly circular shape. A representative dimension D should be determined in the measuring section. At least five equally spaced measurements of D shall be taken, including one at the centre of the measuring section and one at each end. These measurements shall be averaged to be representative of the conduit dimension in the measuring section.
- (h) The surface of the penstock should be properly prepared for clamping the transducers on to it. No trace of paint or rust should be left and the surface should be made smooth and clean so as to ensure a good contact between the conduit surface and the transducer face.



(a) Adequate length of penstock left un-embedded for installing transducers



(b) Transducers of UTTF clamped on a penstock in reflection mode

Fig. 22 : Measurement of discharge with DT-UTTF

9.7.4 Provisions for Discharge Measurement with WT-UTTF in Open Channel

Reference: IEC – 60041 (1991), Appendix J

- (a) The measuring section of the open channel should be chosen as far as possible from any upstream disturbance, such as a bend in the channel that could create asymmetry of the velocity distribution across the width of the channel, swirl, or large scales turbulence.
- (b) The channel cross-section both upstream and downstream of section should be uniform, as a change in cross-section may produce transverse velocity components and distortion of the velocity profile.
- (c) There should be a straight length of the upstream channel, between the measuring section and any important irregularity, of at least ten times the channel width. Similarly, there should be a straight length of at least three times the channel width between the measuring section and any important downstream irregularity.
- (d) A representative value of the channel width shall be determined in the measuring section. Measurements shall be made at least at three cross-sections: one at the centre

of the measuring section and one at each end. At each of these cross-sections, width shall be measured in each horizontal plane of the transducers. These measurements shall be averaged to be representative of the width in the measuring section.

- (e) It should be possible to empty the channel at the measuring section to allow fixing of the transducers on its walls and their alignment.

9.7.5 Provisions for Discharge Measurement with H-ADCP in Open Channel

- (a) The measuring section of the open channel should be chosen as far as possible from any upstream disturbance, such as a bend in the channel that could create asymmetry of the velocity distribution across the width of the channel, swirl, or large scales turbulence.
- (b) The channel cross-section both upstream and downstream of section should be uniform, as a change in cross-section may produce transverse velocity components and distortion of the velocity profile.
- (c) There should be a straight length of the upstream channel, between the measuring section and any important irregularity, of at least ten times of the channel width. Similarly, there should be a straight length of at least three times the channel width between the measuring section and any important downstream irregularity.
- (d) A representative value of the channel width should be determined in the measuring section. Several measurements of the channel width will be taken at various depths as far as possible, which will be then averaged to be representative of the channel width at the measuring section.
- (e) A guide-rail should be rigidly fixed in vertical plane to one of abutments of the channel for the H-ADCP trolley to move in water along the rail in the measuring section (see Fig 23 and Fig 24).
- (f) The measuring location should have good access and enough space on the channel abutment and bank for maneuvering the H-ADCP (see Fig 25).



Fig. 23 : ADCP Trolley



Fig. 24 : Guide rail fixed to the channel wall for guiding movement of ADCP trolley

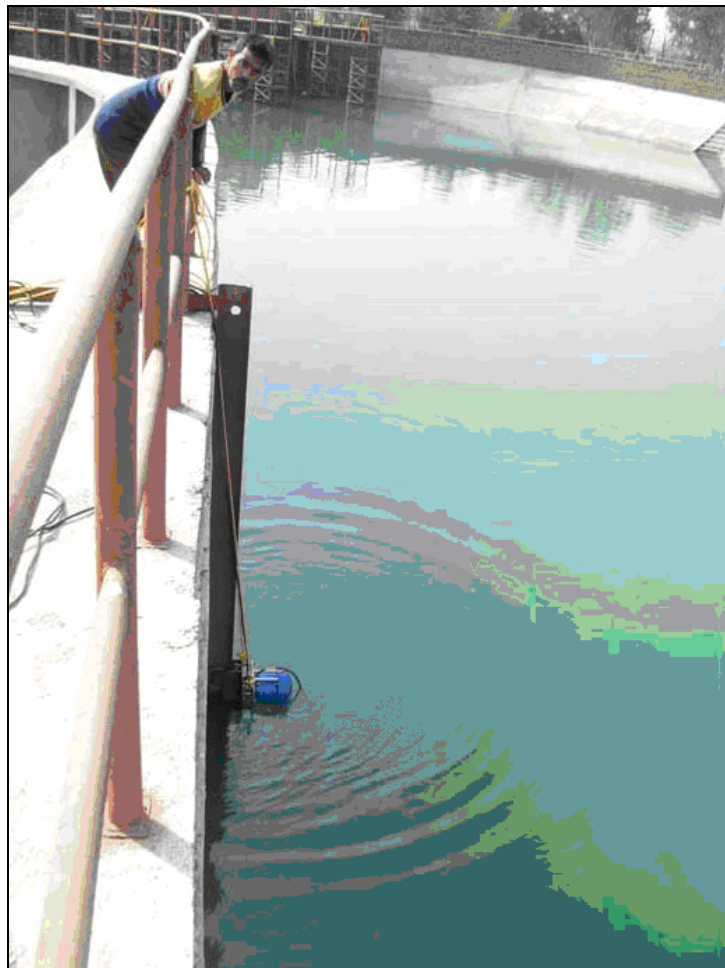

Fig. 25 : Maneuvering ADCP trolley movement on the guide rail

9.7.6 Provision for Discharge Measurement with V-ADCP in Open Channel

- (a) The measuring section of the open channel should be chosen as far as possible from

any upstream disturbance, such as a bend in the channel, which could create swirl or large scales turbulence.

- (b) There should be a straight length of the upstream channel, between the measuring section and any important irregularity, of at least ten times of the channel width. Similarly, there should be a straight length of at least three times the channel width between the measuring section and any important downstream irregularity.
- (c) The measuring location should have good access and enough space on both the abutments and banks of the channel for maneuvering the V-ADCP (see Fig 26).



Fig. 26 : Maneuvering V-ADCP from channel banks

9.8 Provisions for Relative-Discharge Measurement

Reference: IEC-60041(1991), Clause 15.2

The Index Test involves measurement of relative-discharge as opposed to the measurement of absolute-discharge required for unit efficiency test. The index test is highly recommended as it can give some of the following very useful information:

- (i) To determine the relative variation in the unit efficiency with load or gate/valve opening.
- (ii) To determine the correct relationship between runner blade angle and guide vane opening in the case of a double regulated machine.
- (iii) To provide additional test data during the unit efficiency test.

The methods used for measuring the relative discharge are the secondary methods.

The following methods are recommended in the IEC Standard 60041:

- (a) Measurement of pressure difference between suitably located taps on the turbine spiral case (Winter-Kennedy method).
- (b) Measurement of pressure difference between suitably located taps in tubular turbines.
- (c) Measurement of pressure difference between suitably located taps on a bend or taper section of the penstock.
- (d) Single-path ultrasonic transit-time flowmeter.
- (e) Measurement of needle stroke on pelton turbines.
- (f) Measurement by means of a single current meter.

Therefore, it is highly desirable that necessary provisions are made for the measurement of relative discharge, as explained /illustrated below:

9.8.1 Provision of Pressure Taps in Spiral Case of Turbine

Reference: IEC-60041(1991), Clause 15.2.1.1

- (a) In installations with a steel spiral case, the relative discharge can be best measured by the Winter- Kennedy method, which consists in providing a pair of pressure taps on the spiral case appropriately and measuring the differential pressure ‘ Δp ’ between the taps using an electronic differential pressure gauge.
- (b) The relation between the discharge ‘ Q ’ and ‘ Δp ’ is well represented by

$$Q = k (\Delta p)^n$$

where ‘ n ’ is theoretically equal to 0.5.

- (c) The pair of pressure taps should be located in the same radial section of the spiral case, as shown in Fig 27 and illustrated by a photograph in Fig 28.
- (d) The outer tap ‘1’ is located at the outer side of the spiral. The inner tap ‘2’ should be located outside of the stay vanes on a flow line passing midway between the two adjacent stay vanes.
- (e) It is recommended that a second pair of taps be similarly located in another radial section.
- (f) With a horizontal spiral case, the taps should be arranged in the upper half because of the better possibility of purging.
- (g) The pressure taps should not be in proximity to welded joints or abrupt changes in the spiral section.
- (h) The pressure taps should comply with the requirements described in section 9.2.3 and illustrated in Fig 27. Since the differential pressures to be measured may be small, special attention should be given to removing surface irregularities.

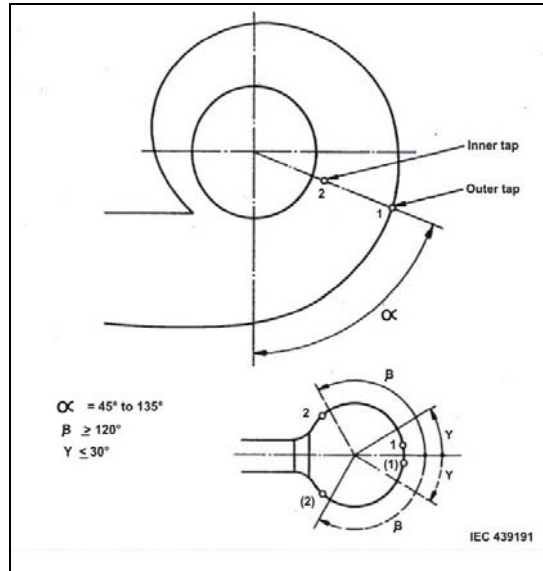

Fig. 27 : Location of pressure taps in steel spiral case

Source: IEC-60041 (1991)



Fig. 28 : Illustration of pressure taps in vertical steel spiral case

9.8.2 Provision of Pressure Taps in Semi-Spiral Case of Turbine

Reference: IEC-60041(1991), Clause 15.2.1.1

- (a) The Winter-Kennedy method (see section 9.8.1) is the best method of relative discharge measurement even for turbines with a concrete semi-spiral case.
- (b) The pressure taps should be located in a radial section of the concrete case as shown in Fig 29.

- (c) It is recommended that two pairs of taps should be provided.
- (d) The outer tap 1 (or 1') should be located sufficiently far from the corners. The inner tap 2 (or 2') should be located outside of the stay vanes on a flow line passing midway between two adjacent stay vanes. A third tap 3 may be arranged on a stay vane, preferable at the elevation of the centre-line of the guide vanes, or on the roof between two stay vanes.
- (e) The pressure taps should comply with the requirements described in section 9.2.3 and illustrated in Fig 29. Since the differential pressures to be measured may be small, special attention should be given to removing surface irregularities.
- (f) The pipes connecting the taps to the differential pressure gauge should slope upward to the gauge with no intermediate high spots where air may be trapped. Valves should be provided at high points for purging (flushing out air). See Fig 30.

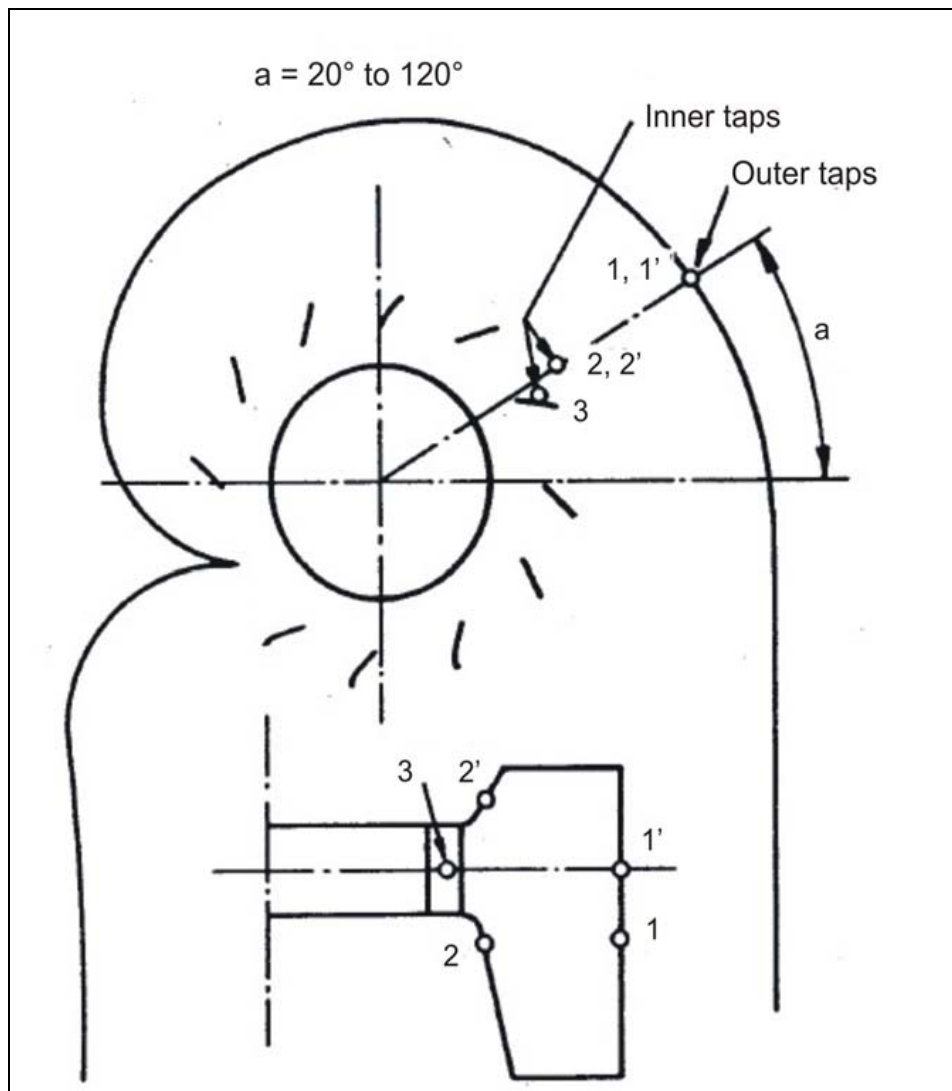

Fig. 29 : Location of pressure taps in concrete semi-spiral case
Source: IEC-60041 (1991)



Fig 30 : Upward sloping pipes and valves for purging

9.8.3 Provision of Pressure Taps in Tubular Turbines

Reference: IEC-60041(1991), Clause 15.2.1.3

- (a) In application of the differential pressure method of measuring relative discharge through a bulb turbine, the taps may be located as shown in Fig 31.
- (b) It is recommended that two pairs of pressure taps should be provided.
- (c) The tap for higher pressure may be arranged at the stagnation point of the bulb (point 1) or of the access shaft (point 1') and tap for lower pressure should be located on the wall directly upstream from the guide vanes, however with sufficient distance from their profile nose at maximum guide vane opening (point 2 or 2').
- (d) Discharge may be assumed proportional to the square root of the differential pressure.
- (e) For all other types of tubular turbines (e.g. pit turbine) analogous application may be made.
- (f) The pressure taps used should comply with the requirements described in section 9.2.3 . Since the differential pressures to be measured may be small, special attention should be given to removing surface irregularities.

9.8.4 Provision of Pressure Taps in Taper Section or Bend in Penstock

Reference: IEC-60041(1991), Clauses 15.2.1.2 & 15.2.3.3

- (a) In case where the provisions described in sections 9.8.1, 9.8.2 or 9.8.3 above do not apply or are not feasible, relative discharge can be obtained by providing a pair of pressure taps in a convergent section of the penstock and measuring the differential pressure between the taps.
- (b) Discharge may be assumed proportional to the square root of the differential pressure.
- (c) Two pressure taps are required to be located, one each at two cross-sections of different areas. The most stable pressure difference will be obtained if both taps are located on the converging part of the pipe. However, if the differential

pressure thus obtained is not large enough, it may be preferable to locate one tap a short distance upstream of the convergent section and the second one not less than half a diameter downstream of the convergent section.

- (d) If a convergent section of penstock is not available or accessible for the purpose as above, then the taps may be provided in a divergent section of the penstock or a bend in the penstock.
- (e) The pressure taps used should comply with the requirements described in section 9.2.3 and illustrated in Fig 31. Since the differential pressures to be measured may be small, special attention should be given to removing surface irregularities.

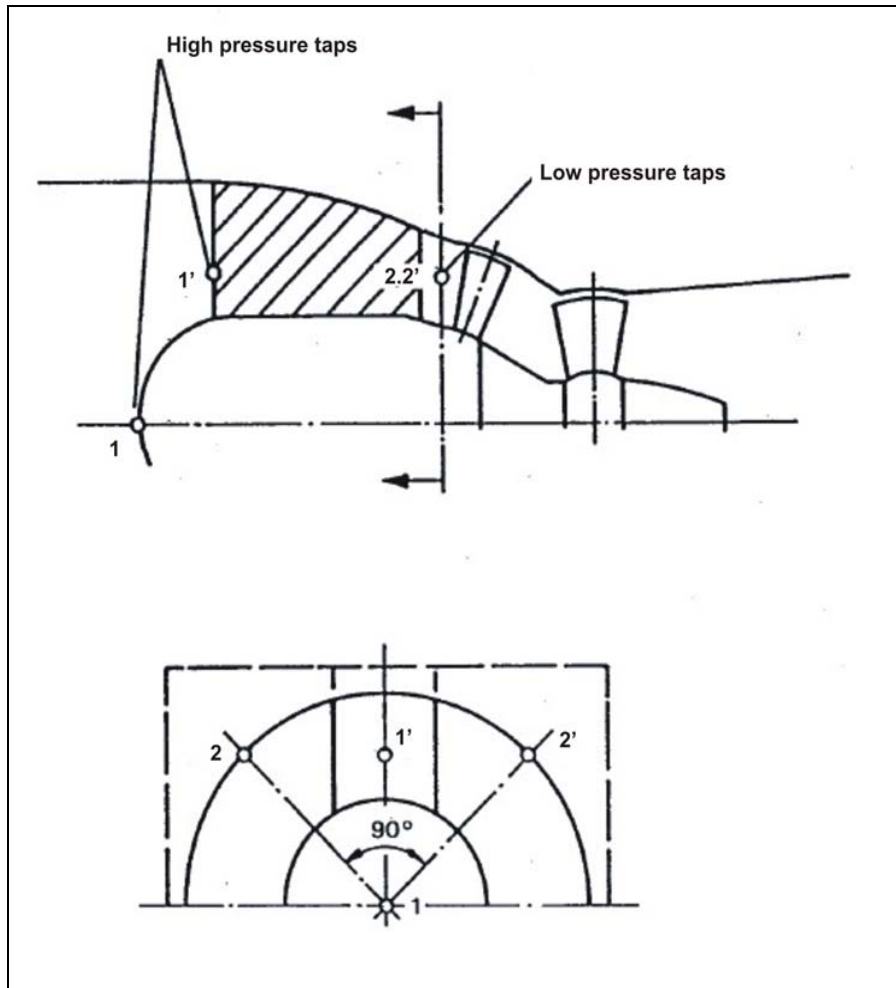

Fig. 31 : Location of taps in bulb turbine

Source: IEC-60041 (1991)

9.8.5 Provisions for Alternative Methods of Discharge Measurement

Reference: IEC-60041(1991), Clauses 15.2.2, 15.2.3.1 and 15.2.3.2

In cases where the provisions described in sections 8.1, 8.2, 8.3 or 8.4 above do not apply or are not feasible, necessary provision should be made for at least one of the alternative methods of relative discharge measurement as described below:

- (a) Relative discharge measurement by acoustic method is suitable due to the good repeatability of measurements and good linear characteristic. One single-path system or a double-plane single-path system, as shown in Fig 32 and Fig 33, respectively, may be sufficient.

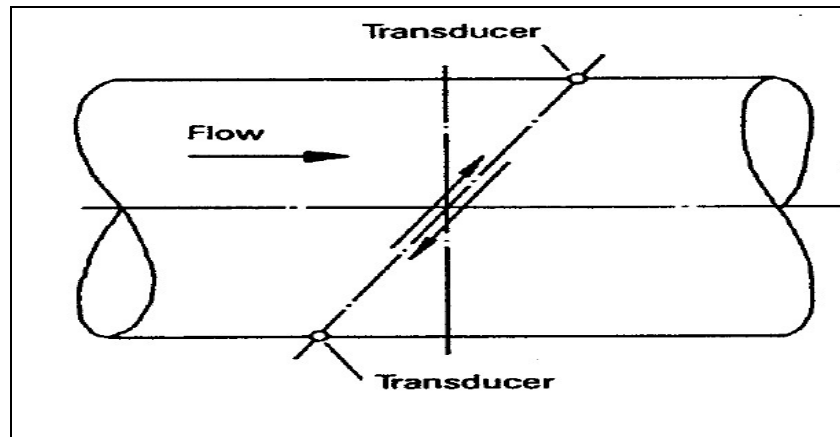

Fig. 32 : Acoustic method of discharge measurement - Single path system

Source: IEC-60041 (1991)

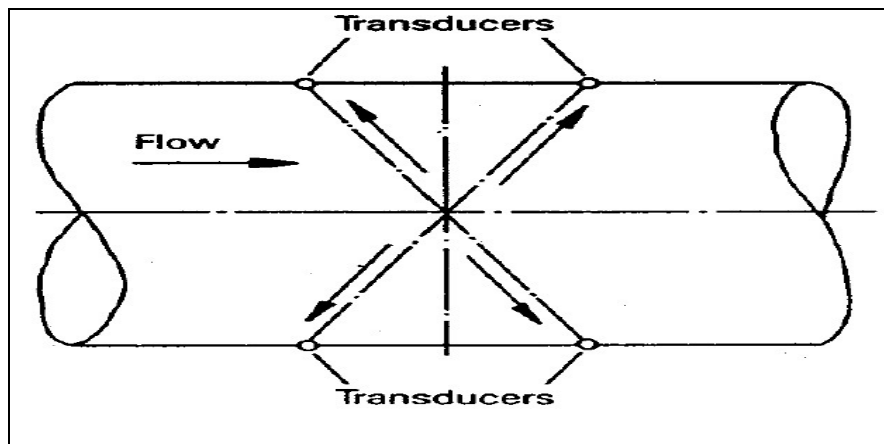

Fig. 33 : Acoustic method of discharge measurement - Double plane single path system

Source: IEC-60041 (1991)

- (b) The stroke of the needle of a Pelton turbine may be used to give relative discharge, provided that the discharge/stroke characteristic shape has been checked by tests on a homologous model of the turbine. Great care should be taken to ensure that during the test the needle, nozzle and support vanes are clean and in good order.
- (c) Relative discharge can also be measured using one single current meter suitably located in the open channel or conduit, as the case may be.

9.9 Provisions for Electrical Power Measurement

Reference: IEC-60041(1991), Clause 12

Electrical power output of generator is required to be measured as one of the parameters, both in the efficiency test and the maximum power output test. Certain provisions are recommended below to facilitate this measurement and to achieve good accuracy. The same provisions also facilitate error checks on panel meters.

9.9.1 Test Terminal Block

- (a) A test terminal block (TTB), which is an inexpensive and standard control-panel accessory (see Fig 34), should be provided on every metering panel.
- (b) The TTB should be provided on the front, usually near the bottom, of the control panel (see Fig 35).
- (c) The TTB shall be appropriately wired to make available the current transformer (CT) and voltage transformer (VT) outputs on it. This will enable connecting a reference meter during testing from outside, without opening the panel or stopping the machine or switching off the machine breaker (see Fig 36).
- (d) The TTB should be of 3-phase 3-wire or of 3-phase 4-wire type, depending on the nature of the machine output.
- (e) Locating the TTB inside a control panel should be avoided, because in that case a reference meter can be connected at the TTB only after opening the panel and working inside the live panel, which can be a safety hazard.
- (f) It should be noted that sliding-link terminals, used as a standard practice to terminate CT outputs inside control panels, are not a substitute for the TTB on the front of the control panels, because a reference meter can be connected at the sliding-link terminals only after opening the panel and working inside the live panel, which can again be a safety hazard.

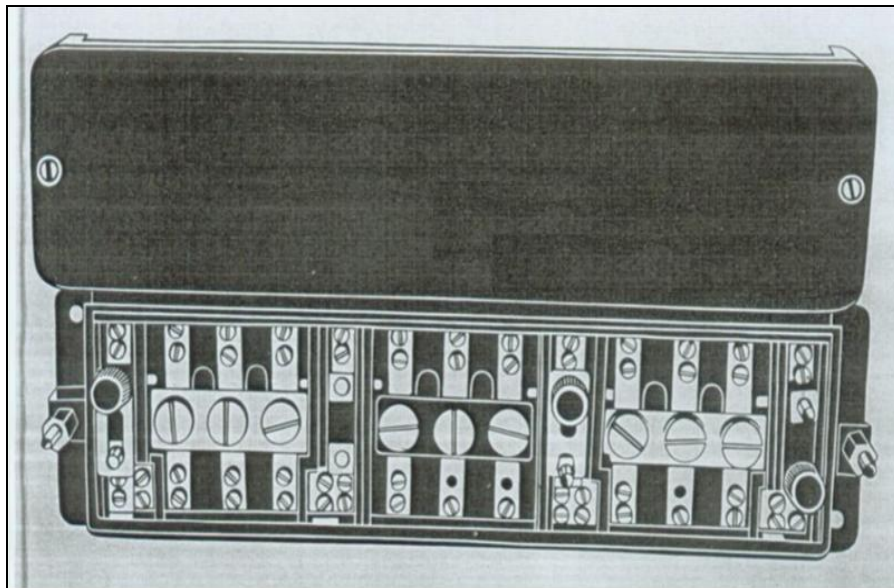

Fig. 34 : A Sample of TTB

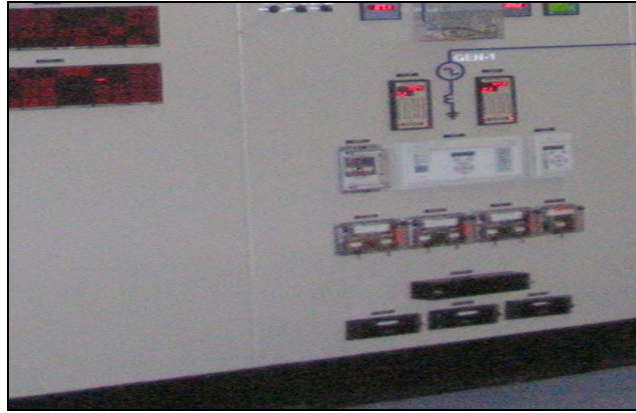

Fig. 35 : TTB (shown with cover in place) fitted on the front of a control panel



Fig. 36 : Reference meter connected at TTB without opening the control panel

9.9.2 Instruments and Measuring Transformers

Reference: IEC-60041(1991), Clause 12.1.1.2.1

- (a) The watt-meters connected for measuring the generator output power should be of accuracy class 0.2 or better.
- (b) The voltmeters and ammeters connected for measuring the generator voltages and currents should be of accuracy class 0.5 or better.
- (c) The measuring transformers, that is, the current and voltage transformers, connected at the output of the generator should be of accuracy class 0.2 or better.

FORMAT OF POWER STATION DATA TO BE SUPPLIED BY OWNER

- (1) To be provided by the Power Station Owner interested in Performance Evaluation to the Evaluating Agency.
- (2) Equipment supplier/contractor may be consulted to obtain relevant information/drawing if not available with the owner
- (3) Please do not leave any column blank, write NA for Not Applicable and DNA for Data Not Available.
- (4) Please note that unless the mandatory information (wherever indicated) is provided, evaluation will not be taken up.

A. GENERAL (*mandatory information*)

Name of Power Station:

Owner of Power Station: (*with tel/fax/email and postal address*)

Location (*Enclose location/route map*)

Nearest Town with Distance:

District:

State:

Longitude:

Latitude:

Altitude:

Nearest Guest-House/Hotel (*with address and distance*):

Details of plant

Type of Power Station (Run-of-River/Dam based/Canal based):

Source of Water:

No. of Generating Units with Capacities:

Maximum and minimum head:

Commissioning Date (for each unit):

B. GENERATING UNITS (*mandatory information*)

1. Turbine

Type:

Shaft (Vertical/Horizontal):

Make:

Rated Head:

Rated Discharge:

Rated Power Output:

Rated Speed:

Speed Increaser Used (None/Gear Box/others):

Flywheel Provided? (Yes/No):

Pressure Taps Provided? (Yes/No):

If yes,

Number:

Size:

Locations:
(Enclose drawing/photograph)

2. Generator

Make:
Type (Synchronous / Induction): (select one)
Rated Speed:
Generator Ratings: _____ kW, _____ pf, _____ kVA, _____ Hz,
_____ kV, Y or D connected stator windings

Designed Overloading (%):

Run-away Speed:

Excitation System (Brushless/Static/Brush-type) : (select one) Exciter Ratings:

3. Voltage Regulator

Type (Digital / Analog): (select one)
Make:
Response Time:
Sensitivity:

4. Governor

Type (Digital /Analog/PLC): (select one)
Make:
Response Time:
Sensitivity:

5. Main Inlet Valve

Make:
Type:
Closing time:

6. Guide Vanes/Wicket Gates/Nozzles

Device (Guide vanes/wicket gates/Nozzles): (select one)
Number:
Closing time:

7. Efficiency of Generating Units

(Enclose efficiency curves/data for turbine and generator from the manufacturers)

8. Any problem observed? If yes, give details:

Turbine:
Generator:
Main Inlet Valve:
Speed Increaser:

Governor:
Exciter:
Voltage Regulator:
Bearings:
Others:

C. WATER CONDUCTOR SYSTEM (*Enclose relevant drawings for applicable components*) (*Mandatory information*)

- 1 Details of weir/Barrage/Dam: Type, dimensions, inlet gate, design discharge for power generation, various levels design, flood discharge
- 2 Details of desilting tank: Discharge, dimensions, number of outlets and sizes
- 3 Head-Race Channel/tunnel/Pipe: Length, cross section (Width, depth, side slopes) lining, discharge
- 4 Details of forebay tank: dimensions, number of outlets, sizes, trash rack arrangement,
- 5 Details of surge tank: Type and dimensions,
- 6 Tail-Race Channel: Length, cross section (Width, depth, side slopes) lining, discharge
- 7 Designed Discharge for power house for all units(in m³/s):
- 8 Single Intake or Individual Intakes for Machines:
- 9 Number and Type of Intake Gates:
 - Type:
 - No. of intake gates per turbine
 - Total no. of intake gates
 - Size
 - Type of hoisting
10. Number and Type of Draft Tube (DT) Gates:
 - Type:
 - No. of DT gates per turbine:
 - Total no. of DT gates:
 - Size
 - Type of hoisting
11. Common Penstock
 - Length:
 - Inside Diameter:
 - Thickness:
 - Material:
 - No of bends
 - No of Expansion Joints
12. Individual Penstocks
 - Length:
 - Inside Diameter:
 - Thickness (various):
 - Material:
13. Spilling Arrangement, dimensions, layout and Discharge Capacity

D. DISCHARGE MEASUREMENT PROVISIONS (*mandatory information*)

1. Do you measure discharge? (Yes / No):

If no, how do you know the discharge?

If yes,

How frequently?

By what method?

Location of Measurement:

Details of Instrument/Method:

(Enclose drawing / photograph)

2. Do you have provision for relative discharge measurement? (Yes/No):

If yes,

Method used (Taper section/Winter-Kennedy/others):

Details: *(Enclose drawing/photograph)*

E. HEAD / LEVEL MEASUREMENT PROVISIONS (*mandatory information*)

1. Do you have provisions for head or pressure measurement? (Yes / No):

If yes,

Location:

Method/ instrument Used:

Size of pressure taps:

Location of pressure taps:

(Enclose drawing / photograph)

2. Do you have provisions for measurement of free water level? (Yes / No):

If yes,

Locations:

Method/ Instrument Used:

(Enclose drawing / photograph)

3. Whether reference elevations marked? (Yes / No):

If yes,

Location (Machine floor/others):

Levels above MSL (in m):

4. Whether elevation of Centre-line of Penstock Marked? (Yes / No):

If yes, its level (in m):

5. Whether elevation of Centre-line of Turbine Marked? (Yes / No):

If yes, its level (in m):

F. POWER CIRCUIT/EQUIPMENT

- (i) Single-line Power Diagram of Power Station: *Please enclose*
- (ii) Power Transformers

Individual Unit Transformers or Common Transformer?

Make:

Number of Transformers:

Transformer Ratings:

Winding Connections:

Cooling type:

Tap Changer Type (Off-load/on-load): (select one)

Tap changer make:

Any Problem Observed? If yes, give details:

- (iii). Auxiliary (Station) Transformers

Make:

Number of Transformers:

Ratings:

Cooling type:

Location:

G. INSTRUMENTATION

- 1. Details of Panel Meters are shown in table A1 below:

Table A1: Details of Panel Meters

| S. No. | Panel Name | Meter Name & Make | Analog (A) or Digital (D)? | Range | Accuracy Class | Quantity |
|--------|------------|-------------------|----------------------------|-------|----------------|----------|
| | | | | | | |
| | | | | | | |
| | | | | | | |
| | | | | | | |

- 1 Details of Temperature Scanner (if any):
- 2 Details of Recorders (if any):
- 3 Details of Data Acquisition System (if any):
- 4 Details of Test Terminal Blocks, if provided are shown in Table A2 below:

Table A2: Details of Test Terminal Blocks

| S. No. | Name of panel | Location of TTB: Inside/Outside panel? |
|--------|---------------|--|
| | | |
| | | |
| | | |
| | | |
| | | |
| | | |
| | | |

6. Details of CTs are shown in table A3 below:

Table A3 : Details of CTs

| <i>Sl. No.</i> | <i>Location</i> | <i>Measuring or Protection CT?</i> | <i>CT Ratio</i> | <i>Accuracy Class</i> |
|----------------|-----------------|------------------------------------|-----------------|-----------------------|
| | | | | |
| | | | | |
| | | | | |
| | | | | |

6.Details of Voltage (Potential) Transformers are shown in table A4 below:

Table A4 : Details of Voltage (Potential) Transformers

| <i>Sl. No.</i> | <i>Location</i> | <i>Measuring or Protection V.T.?</i> | <i>V.T. Ratio</i> | <i>Accuracy Class</i> |
|----------------|-----------------|--------------------------------------|-------------------|-----------------------|
| | | | | |
| | | | | |
| | | | | |
| | | | | |

H. PROTECTION SYSTEM (Enclose relevant panel drawings)

1. Details of Measuring Relays are shown in table A5 below:

Table A5 : Details of Measuring Relays

| <i>S. No.</i> | <i>Name of Panel</i> | <i>Name of Relay</i> | <i>Make</i> | <i>Model</i> |
|---------------|----------------------|----------------------|-------------|--------------|
| | | | | |
| | | | | |
| | | | | |
| | | | | |
| | | | | |

2. Details of Auxiliary / Master/Trip Relays are shown in table A6 below

Table A6 : Details of Auxiliary / Master/Trip Relays

| <i>S. No.</i> | <i>Name of Panel</i> | <i>Name of Relay</i> | <i>Make</i> | <i>Model</i> |
|---------------|----------------------|----------------------|-------------|--------------|
| | | | | |
| | | | | |
| | | | | |
| | | | | |
| | | | | |

3. Details of Circuit Breakers are shown in table A7 below

Table A7 : Details of Circuit Breakers

| <i>S. No.</i> | <i>Breaker Name</i> | <i>Breaker Type (Air/Oil/SF6)</i> | <i>Breaker Location</i> | <i>Make</i> | <i>Model</i> |
|---------------|---------------------|-----------------------------------|-------------------------|-------------|--------------|
| | | | | | |
| | | | | | |
| | | | | | |
| | | | | | |

4. Details of Fault Annunciators (FA) are shown in table A8 below

Table A8 : Details of Fault Annunciators

| <i>S. No.</i> | <i>Name of Panel</i> | <i>Microprocessor or Relay type?</i> | <i>Make of FA</i> | <i>No. of Facia Windows</i> | |
|---------------|----------------------|--------------------------------------|-------------------|-----------------------------|--------------------|
| | | | | <i>Total number</i> | <i>Number used</i> |
| | | | | | |
| | | | | | |
| | | | | | |
| | | | | | |

I. Details of station / plant auxiliaries are shown in table A9 below:

Table A9 : Details of station / plant auxiliaries

| <i>S. No.</i> | <i>Name of Auxiliary</i> | <i>Particulars/Ratings/Make/Quantity</i> |
|---------------|---|--|
| 1. | Station AC Supply | |
| 2. | Station DC Supply | |
| 3. | Oil Pumping Units | |
| 4. | Bearing Cooling System | |
| 5. | Generator Cooling System | |
| 6. | Transformer Cooling System | |
| 7. | Vacuum Pumps | |
| 8. | Air Compressors | |
| 9. | Drainage System | |
| 10. | Dewatering System | |
| 11. | Equipment Handling Crane (span and Capacity main/auxiliary) | |
| 12. | Hoists | |
| 13. | Power house dimension(Length, Width and height above machine | |
| 14. | (Others) | |

J. DETAILS OF ANY OTHER EQUIPMENT *not covered above (like SCADA) or any other information relevant to the Performance testing of your Power Station:*

K. FLOW DURATION CURVE: *Enclose a photocopy of the flow duration curve and data as included in the DPR (mandatory information).*

L. TESTS CONDUCTED AT SITE, IF ANY *(Enclose report)*

M. DATA REGARDING CONFORMITY TO STANDARDS *(mandatory information)*

Data regarding conformity to standards shall be as shown in table A10 below:

Table A10 : Data regarding conformity to standards

| S. No. | Name of equipment | Make | Standard(s) to which equipment conforms | Evidence of conformity to standard(s) ^a | | |
|--------|---------------------|------|---|--|--------------------------|--|
| | | | | Certificate of manufacturer ^b | Test report ^c | Certification mark on the equipment ^d |
| (1) | (2) | (3) | (4) | (5) | (6) | (7) |
| 1. | Turbines | | | | | |
| 2. | Generators | | | | | |
| 3. | Power Transformers | | | | | |
| 4. | CTs | | | | | |
| 5. | VTs | | | | | |
| 6. | Protective Relays | | | | | |
| 7. | HT Circuit Breakers | | | | | |
| 8. | LT Circuit Breakers | | | | | |
| 9. | PLC | | | | | |
| 10. | SCADA System | | | | | |
| 11. | Governor | | | | | |
| 12. | Excitation System | | | | | |
| 13. | AVR | | | | | |
| 14. | Auto Synchronizer | | | | | |
| 15. | Panel Meters | | | | | |
| 16. | Motors | | | | | |
| 17. | Cables | | | | | |
| 18. | Batteries | | | | | |
| 19. | Pumps | | | | | |
| 20. | Crane | | | | | |
| 21. | (Others) | | | | | |

^a At least one of the three evidences should be there. So at least one of the three columns, namely (5), (6) and (7), should have 'YES'. Your YES statement will be verified by the test team at site.

^b Certificate of manufacturer declaring that the equipment conforms to the standard stated in column (4).

^c Test report for the equipment mentioning clearly that the equipment conforms to the standard stated in column (4).

^d The certification mark by the standards organization such as BIS showing that the equipment conforms to the standard stated in column (4).

N. DETAILS FOR CLEARANCES OBTAINED FOR PROJECT (*mandatory information*)

Details for clearances obtained for project shall be as per table A11 below

Table A11 : Details for clearances obtained for project

| Name of the Clearance | Date of application/submission | Date of approval/clearance |
|---|---------------------------------------|-----------------------------------|
| 1. Power Purchase Agreement | | |
| 2. Pollution Control | | |
| 3. Land Acquisition | | |
| (a) Forest Land | | |
| (b) Private Land | | |
| (c) Gram Panchayat | | |
| 4. State Irrigation Department | | |
| 5. Financing Institute (loan) | | |
| 6. State Nodal Agency for Techno-Economic Clearance | | |
| 7. Labour | | |
| 8. Explosives License | | |
| 9. Wireless Communication | | |
| 10. Wild life | | |
| 11. Fisheries | | |
| 12. Archaeology | | |
| 13. PWD | | |
| 14. (Any other clearance) | | |

O. PERMANENT /TEMPORAY BENCH MARK AT POWER HOUSE

Location:

Elevation(in m)

P. CHECK LIST OF ENCLOSURES (*Please fill in enclosure numbers, such as I, II etc. and mark the same on the enclosures*) (*mandatory information*)

Check list of enclosures shall be as per table A12 below:

Table A12 : Check list of enclosures

| <i>Section No.</i> | <i>Name of enclosure</i> | <i>Enclosure No.</i> |
|--------------------|--|----------------------|
| A-3 | Location map or route map | |
| B-1 | Drawing/photograph showing pressure taps on turbine inlet or penstock | |
| B-7 | Turbine efficiency curves/data | |
| B-7 | Generator efficiency curves/data | |
| C | Drawing for general layout of works showing from diversion to tail race | |
| | Drawing for Plan and L-section of Weir/barrage/dam | |
| | Drawing for Plan and L-section of water conductor system | |
| | Drawing for cross section of power channel, forebay tank, tail race channel | |
| | Drawing for details of intake gates | |
| | Drawing for profile of penstock (plan and section)with details like thickness at each location | |
| | Drawing for plan of Power House Building | |
| | Drawing for X-Section of Power House | |
| | Drawing for L-Section of Power House showing turbine inlet to outlet | |
| | Drawing for plan and section of tail race channel | |
| D-1 | Drawing /photograph showing provisions for discharge Measurement | |
| D-2 | Drawing /photograph showing provisions for relative discharge measurement | |
| E-1 | Drawing/photograph showing provisions for measurement of water head or pressure | |
| E-2 | Drawing/photograph showing provisions for measurement of free water level | |
| | Photographs Showing diversion weir, diversion channel at few places, intake gates with hoisting and location for fixing the pressure transducer, tailrace channel and exit details of tailrace. | |
| F-1 | Single-line power diagram | |
| K | Flow duration data and curve, as included in DPR | |
| L | Report of tests conducted earlier, if any | |

ANNEXURE 2

FORMAT OF GENERATION DATA TO BE SUPPLIED BY OWNER

A. Summary of Month-Wise Actual and Projected Generations

| <i>Month and Year</i> | <i>Actual Total Generation (million units)</i> | <i>Projected Generation as per DPR (million units)</i> | <i>Ratio of Actual- to- Projected Generations (percent)</i> | <i>Remark (Above or below 80%)</i> |
|-----------------------|--|--|---|------------------------------------|
| | | | | |
| | | | | |
| | | | | |
| | | | | |
| | | | | |
| | | | | |
| | | | | |
| | | | | |
| | | | | |
| | | | | |
| | | | | |
| | | | | |
| | | | | |
| | | | | |

B. Daily Generation Record for _____ (specify month & year)
(one sheet for each month)

| <i>Date (dd/mm/yy)</i> | <i>Machine-wise Actual Generation (in million units)</i> | | | | <i>Remarks</i> |
|------------------------|--|------------------|------------------|--------------|----------------|
| | <i>Machine#1</i> | <i>Machine#2</i> | <i>Machine#3</i> | <i>Total</i> | |
| | | | | | |

Place: _____
Date: _____

Signature: _____
Name: _____
Designation: _____
Seal: _____